

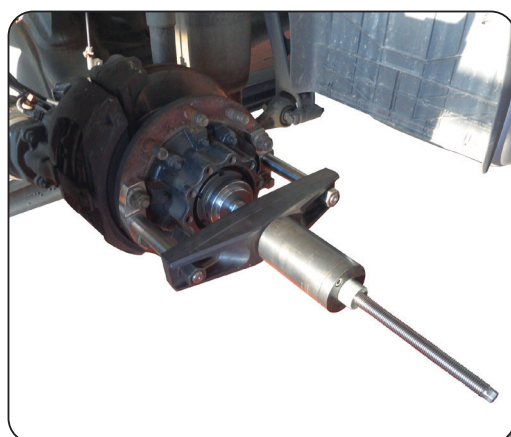

## KL-1005-100 A

### Wheel Hub Puller Set for Commercial Vehicles

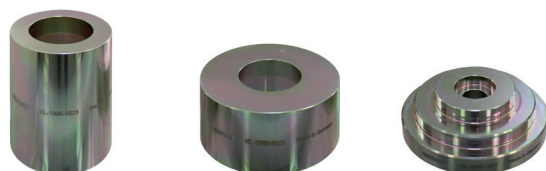
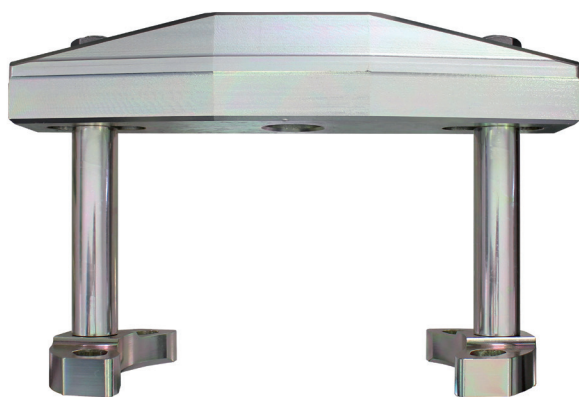

**Operating instructions** EN  
⚠ Read and understand before use!

[www.gedore-automotive.com](http://www.gedore-automotive.com)



#### GEDORE Automotive GmbH

Breslauer Straße 41  
78166 - Donaueschingen  
Postfach 1329  
78154 Donaueschingen - GERMANY

☎ +49 (0) 771 / 8 32 23-0  
☎ +49 (0) 771 / 8 32 23-90  
✉ info.gam@gedore.com  
🌐 gedore-automotive.com

#### GEDORE TOOLS, INC.

Only for USA, Canada & Mexico / Sólo para EE.UU., Canadá y México  
Seulement pour les USA, le Canada et le Mexique  
7187 Bryhawke Circle, Suite 700  
North Charleston, SC 29418, USA

☎ +1-843 / 225 50 15  
☎ +1-843 / 225 50 20  
✉ info@gedoretools.com  
🌐 gedore.com

Version 1 - 01/2022

1005-100A\_EN200508.indd



**ENGLISH**

**EN**

EN

## Manufacturer's address

**GEDORE Automotive GmbH**

Breslauer Straße 41 // 78166 Donaueschingen - GERMANY

+49 (0)771/83223-71 // [info.gam@gedore.com](mailto:info.gam@gedore.com)

## Imprint

In the course of improvement and adaptation to the state of the art, we reserve the right to make changes with regard to appearance, dimensions, weights and properties, and performance.

This does not imply any claim to correction or subsequent delivery of already delivered products. Deletions can be made at any time without any legal claim arising.

Instructions for use and safety are not binding. They never substitute for any legal or trade association regulations.

We do not accept any liability for printing errors.

Any reproduction, in whole or in part, requires the prior written consent of **GEDORE Automotive GmbH**.

All rights reserved worldwide. © Copyright by **GEDORE Automotive GmbH**, Donaueschingen (GERMANY)

We refer to our general terms and conditions which  
can be found in the imprint at:

[www.gedore-automotive.com](http://www.gedore-automotive.com)



# Contents

<b>1. IMPORTANT safety regulations and warnings</b> .....	<b>4</b>
1.1 Target group .....	4
1.2 Intended use .....	4
1.3 Misuse/abuse.....	4
1.4 Personal protective equipment.....	4
1.5 Basic warnings .....	5
1.6 Work environment .....	6
1.7 Handling .....	6
1.8 Emissions .....	6
1.9 Maintenance .....	6
1.10 Troubleshooting.....	6
<b>2. Product description</b> .....	<b>7</b>
2.1 KL-1005-100 A - wheel hub puller set for commercial vehicles .....	7
2.2 Scope of delivery .....	7
2.3 Specifications .....	7
<b>3. Preparation</b> .....	<b>8</b>
3.1 Checking the scope of delivery.....	8
3.2 Necessary drive .....	8
3.3 Preparing the tool .....	8
3.4 Preparing the vehicle .....	8
<b>4. Typical application</b> .....	<b>9</b>
<b>5. Care and storage</b> .....	<b>12</b>
<b>6. Maintenance and repair</b> .....	<b>12</b>
<b>7. Component overview</b> .....	<b>12</b>
<b>8. Environmentally friendly disposal</b> .....	<b>12</b>
<b>9. Manufacturer's address</b> .....	<b>12</b>

## 1. IMPORTANT safety regulations and warnings

### **⚠ WARNING**

Read and understand the operating instructions before you start using the wheel hub puller. Misuse can result in **DEATH** or **SEVERE INJURIES**.

These operating instructions are an integral part of the wheel hub puller. Keep them at a safe place for future reference, and always pass them on to subsequent users of the wheel hub puller.

The purchaser of the wheel hub extractor **must** ensure that the user has read and understood the operating instructions completely before he or she uses the wheel hub extractor.

The operating instructions **must** be available for the user of the wheel hub puller at any time.

### 1.1 Target group

These operating instructions are intended to be used by skilled personnel in motor vehicle workshops.

The wheel hub puller may only be used by trained specialists in motor vehicle workshops who are familiar with the safe handling of special vehicle tools.

- **Never** allow unauthorised persons or minors to use the wheel hub puller!

### 1.2 Intended use

The wheel hub puller is **only intended** for pulling wheel hubs of commercial vehicles!

The wheel hub puller **may only** be used to a **max. load of 28t!**

The wheel hub puller may **only be used** by skilled personnel in motor vehicle workshops!

The wheel hub puller **may** only be operated with muscle power!

The wheel hub puller **may only be used** as described in the operating instructions!

- Any other use can result in **DEATH** or **SEVERE INJURIES** !

### 1.3 Misuse/abuse

The wheel hub puller **must never be** operated by machines!

**Never** make any unauthorised modifications or rebuilds on the wheel hub puller!

- The wheel hub puller **may only** be used in a way as described in **Chapter 1.2 - Intended use**. Any other use can result in **DEATH** or **SEVERE INJURIES** !

### 1.4 Personal protective equipment

When working with the wheel hub puller, **always** wear your personal protective equipment to protect yourself. The wheel hub puller can bring about mechanical hazards such as crushing, cutting and shock injuries.



Always wear **EYE PROTECTION** (see OSHA 29 CFR 1910.133 and ANSI Z87) when using the wheel hub puller to protect yourself against flying parts or particles.

- When working with the wheel hub puller, flying parts or particles can cause **injuries to your eyes!**



Always wear **PROTECTIVE GLOVES** when using the strut spring compressor to protect yourself against sharp edges and crushing between parts.

- When working with the wheel hub puller, sharp edges and crushing between parts can cause **injuries to your hands!**





Always wear **SAFETY SHOES** with anti-slip soles and steel toe cap (see OSHA 29 CFR 1910.136 and ANSI Z41) when using the wheel hub puller to protect yourself against falling parts.

- When working with the wheel hub puller, falling parts can cause **injuries to your feet and toes!**

## 1.5 Basic warnings

**For better differentiation, warnings in these operating instructions are classified as follows:**

Warning sign	Meaning
 <b>WARNING</b>	<b>Indicates</b> a hazardous situation which, if not avoided, could cause <b>DEATH</b> or <b>SEVERE INJURIES</b> .
 <b>CAUTION</b>	<b>Indicates</b> a hazardous situation which, if not avoided, could cause <b>MODERATE</b> or <b>MINOR INJURIES</b> .
<b>CAUTION</b>	<b>Indicates</b> a situation which, if not avoided, can cause damage to the tool or an object in its vicinity.
	<b>Reference</b> to useful information and tips.

### **WARNING - HAZARD from MISUSE**

Very high forces act when pulling wheel hubs. The wheel hub puller can break or slip if it is used improperly. This can cause **DEATH** or **SEVERE INJURIES** by parts being catapulted around!

- Read and understand **all** instructions, safety notes and warnings regarding the operation of the wheel hub puller!
- **Always** work on the vehicle in accordance with the safety regulations of the vehicle manufacturer!
- **Never** operate the wheel hub puller with a machine-operated drive.
- Note that the strut spring compressor is **only** used to pre-tension commercial vehicle wheel hub pullers!
- **Always** mount the wheel hub puller properly and securely according to the specifications on the wheel hub!
- **Never** beat the wheel hub puller with a hammer or anything similar!
- Use **only genuine GEDORE Automotive** spare parts and accessories.
- **Always** wear your personal protective equipment (safety goggles, protective gloves, safety shoes) when working!

### **WARNING - HAZARD from OVERLOAD**

Very high forces act when pulling wheel hubs. The wheel hub puller can break or slip if it is overloaded. This can cause **DEATH** or **SEVERE INJURIES** by parts being catapulted around!

- **Never** exceed the **maximum load** of the wheel hub puller of **28t**!
- **Never** operate the wheel hub puller with a machine-operated drive.
- **Never** use the wheel hub puller when its damaged!
- **Always** wear your personal protective equipment (safety goggles, protective gloves, safety shoes) when working!

### **WARNING - HAZARD from FALLING**

The wheel hub puller can drop during preparation and operation, and this can lead to **SEVERE INJURY**!

- Deposit the wheel hub puller **securely** against falling down, e.g. on a workbench!
- **Always** mount the wheel hub puller properly and securely according to the specifications on the wheel hub!
- **Never** leave the wheel hub puller unattended at the vehicle
- **Always** wear your personal protective equipment (safety goggles, protective gloves, safety shoes) when working!

### **ATTENTION - RISK of DAMAGE**

There is a risk of damaging the wheel hub and the wheel hub puller.

- Always observe vehicle-specific application procedures in the vehicle manufacturer's repair guide.
- Always mount the wheel hub puller properly and securely according to the specifications on the wheel hub!

## 1.6 Work environment

For your safety, **only** use the wheel hub puller in a safe working environment.

- The workplace **must** be clean and tidy.
- The workplace **must** be sufficiently large and illuminated.
- The workplace **must** be located on a solid and non-skidding floor.
- The workplace **must** be safeguarded against access of unauthorised persons.
- The workplace **must** have a room temperature between -10°C and +40°C.

## 1.7 Handling

### ⚠ WARNING

For your personal safety, **always** observe the following safety precautions to avoid injuries and material damages as a result of misuse and unsafe handling of the wheel hub puller. Misuse can result in **DEATH** or **SEVERE INJURIES**.

- **Before use**, read **all** related instructions and warnings for the operation of the wheel hub puller!
  - Always observe **additional** vehicle-specific application procedures in the vehicle manufacturer's repair guide!
  - **Never** use the wheel hub puller when you are tired or under the influence of alcohol, drugs, or medication!
  - Check the wheel hub puller for damage **before each use!**
  - **Never** use the wheel hub puller when its damaged!
  - **Always** ensure that no other persons are present in the working area while working with the wheel hub puller and, if necessary, ask them to leave the area **immediately!**
- Never** exceed the **maximum loading capacity** of the wheel hub puller!
- **Always** keep hair, clothing, and gloves away from moving parts!
  - Interrupt your work **immediately** if you are unsure about using the wheel hub puller, and **contact** the customer service department of **GEDORE Automotive GmbH if necessary!**

## 1.8 Emissions

Molybdenum disulphide paste may leak when the wheel hub puller is used and may cause skin irritation when in contact with the skin, and also pose a risk to the environment.

- After skin contact, clean the affected area **immediately** with a fat-dissolving soap.
- Immediately remove leaking molybdenum disulphide paste with a cleaning cloth and dispose of in an environmentally acceptable manner.

## 1.9 Maintenance

The spindle on the wheel hub puller may be damaged

- **Before each use**, check the spindle on the wheel hub puller for damage and soiling, clean it if necessary, and lubricate it **only** with molybdenum disulphide paste! (For example, **GEDORE Automotive** molybdenum disulphide paste - **KL-0014-0030**)

## 1.10 Troubleshooting

**Always** perform maintenance work on the wheel hub puller when the system is depressurised!

**Problem:** Hydraulic oil may leak on the hydraulic clutch of the hydraulic cylinder or the hand pump.

**Reason:** The hydraulic clutch is dirty or was not properly connected.

**Remedy:** If necessary, clean the hydraulic clutch and connect it properly.

## 2. Product description

### 2.1 KL-1005-100 A - wheel hub puller set for commercial vehicles

Universal fit suitable for wheel hubs of commercial vehicles (as well as wheel hubs with integrated compact wheel bearing) with removable hub caps on the axle systems with a hole circle  $\varnothing$  of 8x275 and 10x335 for BPW, SAF and ZF front and rear axle. Installed for example in Mercedes Benz (Actros [only rear axle]) (Citaro bus [ZF axle]), MAN (TGA [only rear axle]), Renault, Volvo, Iveco, Scania, DAF etc.

The wheel hub puller permits quick and professional removing of wheel hub with removable hub caps. The wheel hub is pulled against the wheel studs and the thrust piece enable a support in the middle via the axle tube. In connection with the 28t hydraulic cylinder with hand pump (accessories) tightly stuck wheel hubs may be pulled easily.

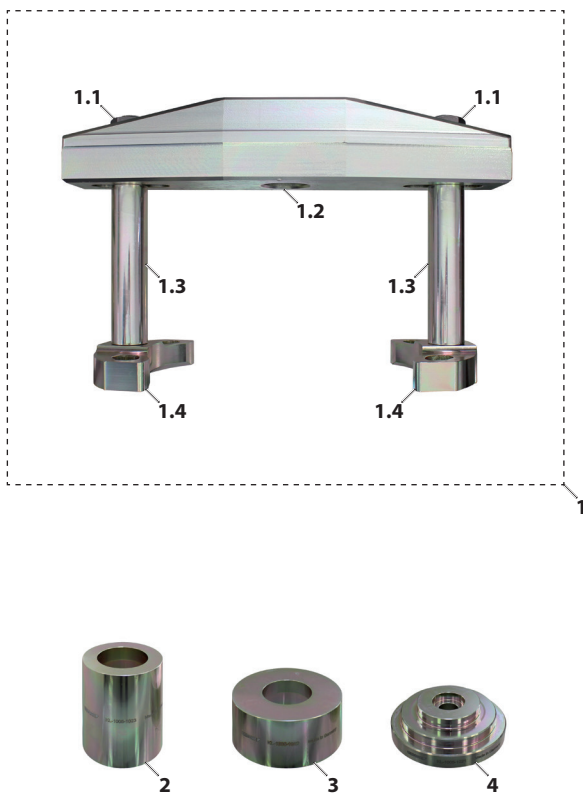

### 2.2 Scope of delivery:

Item	Part no.	Description	Qty.
1	KL-1005-101 A	Base frame	1
1.1	KL-1005-1014	SK collar nut	2
1.2	KL-1005-1011	Base plate	1
1.3	KL-1005-1013	Pull rod	2
1.4	KL-1005-1012 A	Base	2
2	KL-1005-1023	Pressure sleeve (SAF axle)	1
3	KL-1005-1022	Pressure sleeve (ZF axle)	1
4	KL-1005-1021	Thrust piece (universal)	1

### 2.3 Specifications:

Max. load of tool kit: ..... 28t

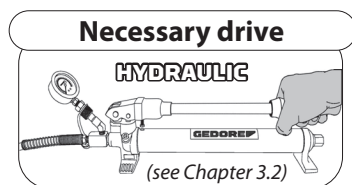

**Fig. 1:** Necessary drive

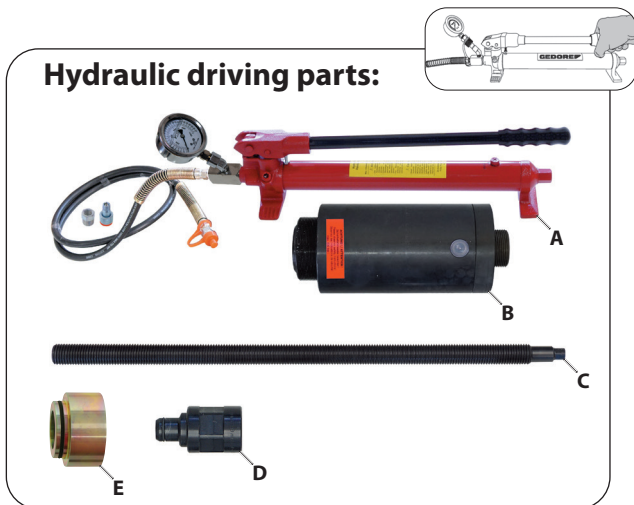

**Fig. 2:** Preparing the tool

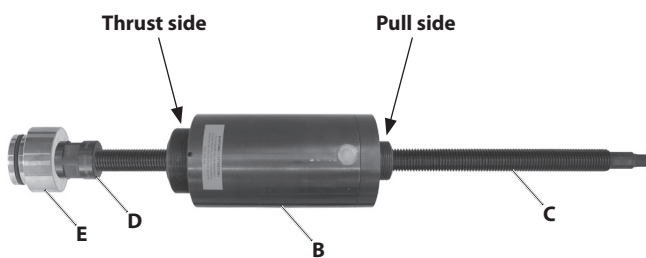

**Fig. 3:** Preparing the vehicle

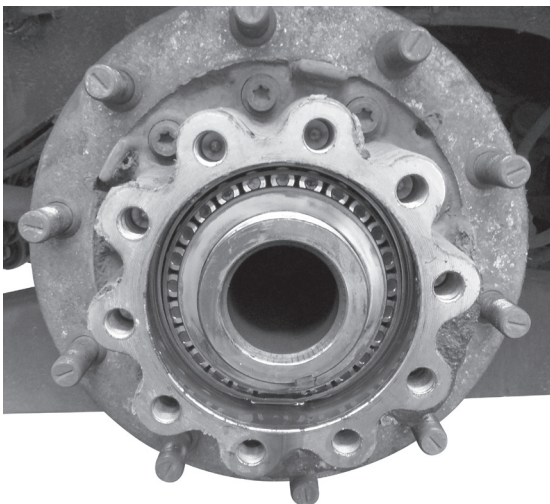

## 3. Preparation

Prior to using the wheel hub puller for the first time, check and ensure that all parts of the scope of delivery are available. Follow the instructions below.

### 3.1 Checking the scope of delivery

### 3.2 Necessary drive

#### ⚠ WARNING

Using unsuitable driving components can cause **DEATH** or **SEVERE INJURIES**.

- The wheel hub puller shall **only** be actuated with suitable drive components and/or hydraulic cylinder/pump combinations which ensure safe operation!
- **Always** operate the wheel hub puller manually with muscle power and **never** with a machine!
- Use **only** genuine **GEDORE** Automotive accessories.

#### Hydraulic driving parts: (see Fig. 1)

Item	Part no.	Description
A	KL-0215-35 M28	Hydraulic pump with 28t manometer
B	KL-0040-2800	Hydraulic cylinder 28t
C	KL-0040-2812-1	Thrust spindle M24
D	KL-0040-2812-5	Thrust nut M24
E	KL-0039-1002	Adapter for clamping nut

① Drive parts, see *GEDORE-Automotive main catalogue*.

### 3.3 Preparing the tool.

1. Prepare the hydraulic cylinder [B], accordingly as shown in Fig. 2

① Observe the pull or the thrust side of the hydraulic cylinder [B]!

### 3.4 Preparing the vehicle

1. Lift the vehicle safely according to the manufacturer's instructions and loosen or prepare all necessary parts for pulling on the wheel hub.

#### **For example:**

Remove the wheel, remove the hub cap, loosen and remove the nut on the wheel bearing.



**Fig. 4:** Mount the base frame [1].

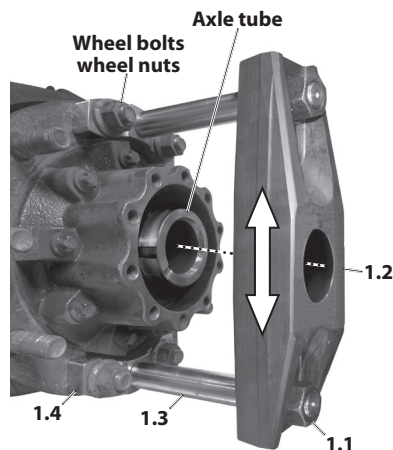

**Fig. 5:** Screw in the hydraulic cylinder [B].

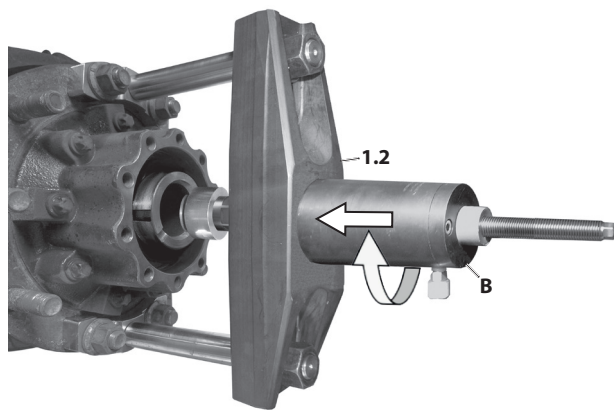

**Fig. 6:** Mount the pressure sleeve [2].

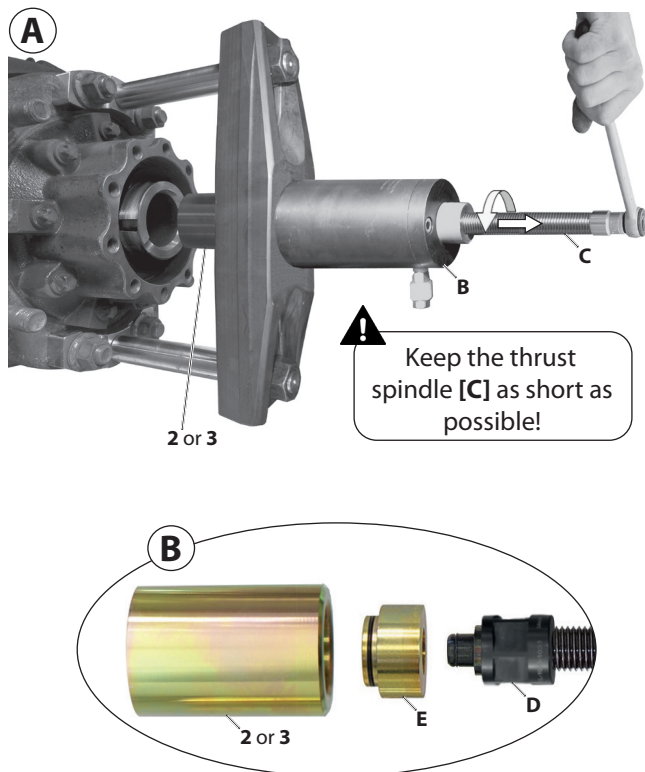

## 4. Typical application

This typical application describes the hydraulic pulling of a wheel hub with integrated compact wheel bearing directly on the vehicle.

1. The base frame [1] has to be adjusted according to the hole circle diameter of the wheel hub.

Therefore, loosen the collar nuts [1.1] a little bit anti-clockwise and move the pull rods [1.3] according to the hole circle diameter of the wheel hub.

Then, tighten the collar nuts [1.1] clockwise with **50Nm** and thereby pay attention to the central adjustment of the base plate [1.2] to the axle tube. (**Fig. 4**)

### **⚠ WARNING**

*In the event of an incorrect assembly of the base frame [1] there is a risk of parts breaking and being thrown around when the wheel hub is pulled off, this can cause **DEATH** or **SEVERE INJURIES**.*

- **Always** tighten the wheel hub puller against 4 wheel bolts on the wheel hub!

2. Mount the base frame [1] as shown in **Fig. 4** over the base [1.4] onto the wheel bolts on the vehicle and secure with 4 wheel nuts with **50Nm**.

3. Screw the prepared hydraulic cylinder [B] on the base plate [1.2] until it is shortly before the stop as shown in **Fig. 5**

### **CAUTION**

*The thrust spindle [C] can be damaged when pulling off the wheel hub.*

- Hold the thrust spindle [C] as short as possible, in order to avoid deformation or damage!
- Use the suitable pressure sleeve [2 or 3], which must be in full and secure contact with the axle tube and be smaller than the inner dia. of the wheel hub!

4. Screw the thrust spindle [C] anti-clockwise in the hydraulic cylinder [B]. (**Fig. 6 A**)

Select the suitable pressure sleeve [2 or 3] according to the axle tube dia. and mount it on the adapter [E]. (**Fig. 6 A+B**)

- ⓘ When pulling off the wheel hub the, the loosening torque can be extremely high, therefore keep the thrust spindle [C] on the hydraulic cylinder [B] as short as possible and use the pressure sleeve [2 or 3] as a spacer.

**Fig. 7:** Insert the thrust piece [4].

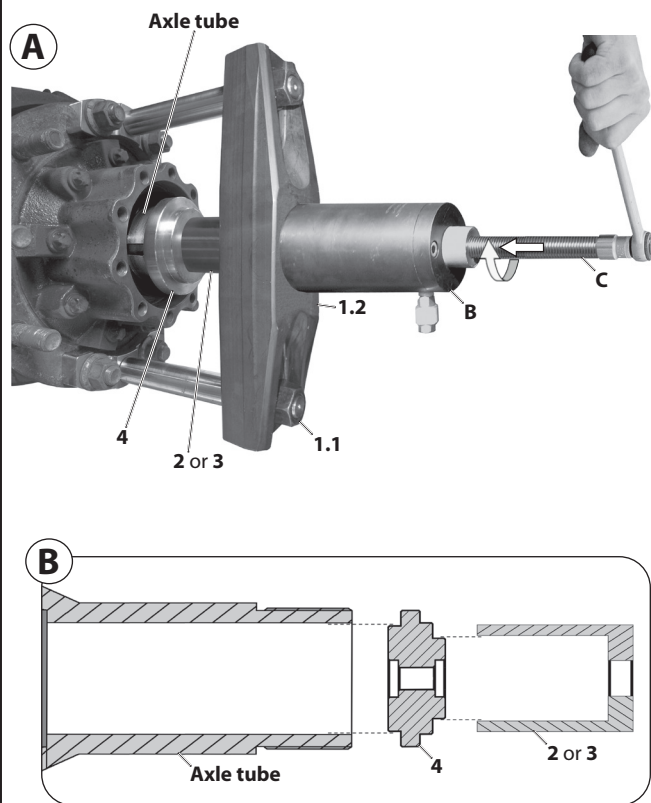

## CAUTION

The axle tube and the thrust spindle [C] can be damaged when pulling off the wheel hub.

- Align the thrust piece [4] so that it lies fully and centrally on the axle tube and engages securely via the collar to prevent slipping! (Fig. 7 B)
- Pay attention to the central adjustment of the base plate [1.2] to the axle tube! If necessary, loosen the collar nuts [1.1], align the base plate [1.2] and tighten the collar nuts [1.1] again with 50Nm.

5. Thrust piece [4] has two application sides. Align it according to the axle tube and insert it. (Fig. 7 B)

Then screw the thrust spindle [C] clockwise until the pressure sleeve [2 or 3] is in complete and secure contact with the thrust piece [4]. (Fig. 7 A+B)

## WARNING

Using unsuitable driving components can cause **severe or fatal injuries**.

- The wheel hub puller shall **only** be actuated with suitable drive components and/or hydraulic cylinder/pump combinations which ensure safe operation!
- **Always** operate the wheel hub puller manually with muscle power and **never** with a machine!

**Fig. 8:** Pull off the wheel hub first.

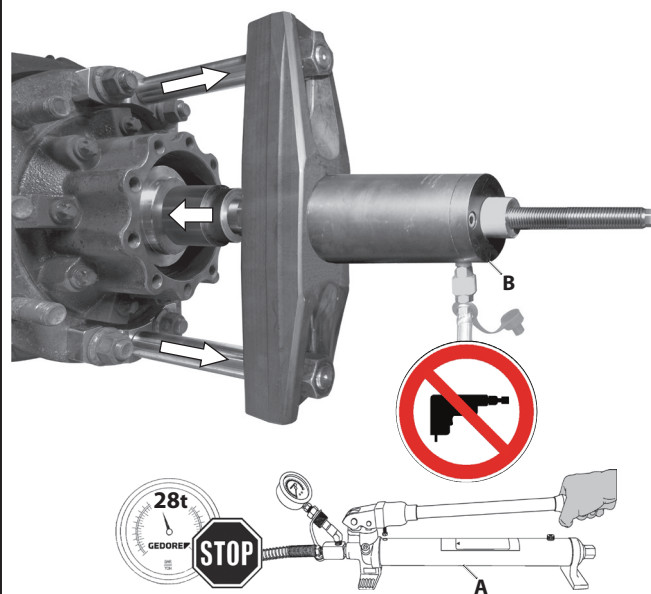

Max. stroke of the hydr. cyl. [B] is 50mm!

As soon as it is reached: Stop pulling off, release the pressure on hydr. pump [A], screw in thrust spindle [C], continue pulling off.

6. Connect hydraulic pump [A] to hydraulic cylinder [B].

## CAUTION

The thrust spindle [C] and the wheel hub can be damaged when pulling off the wheel hub.

- **Immediately** interrupt the pulling process when the thrust piece [C] lies on the compact wheel bearing.

## WARNING

When pulling off wheel hubs there is a risk of breakage and flinging around, as well as heavy parts falling off, which can lead to **DEATH** or **SEVERE INJURIES**.

- Make sure that the wheel hub puller is **always** secured by 4x wheel bolts on the wheel hub!
- **Always** operate the wheel hub puller manually with muscle power and **never** with a machine!
- **Never** exceed the **maximum load** of 28t!
- **Never** stand in axial extension of the pressure spindle [C].
- Pull off the wheel hub **only** to the extent that it sits loosely on the axle tube.
- **Always** wear your personal protective equipment (safety goggles, protective gloves, safety shoes) when working!

7. Actuate hydraulic pump [A] and pull the wheel hub **in the first step** to an extent that the thrust piece [4] lies on the wheel bearing. (Fig. 8)

**Fig. 9:** Remove the thrust piece [4], screw in the thrust spindle [C].

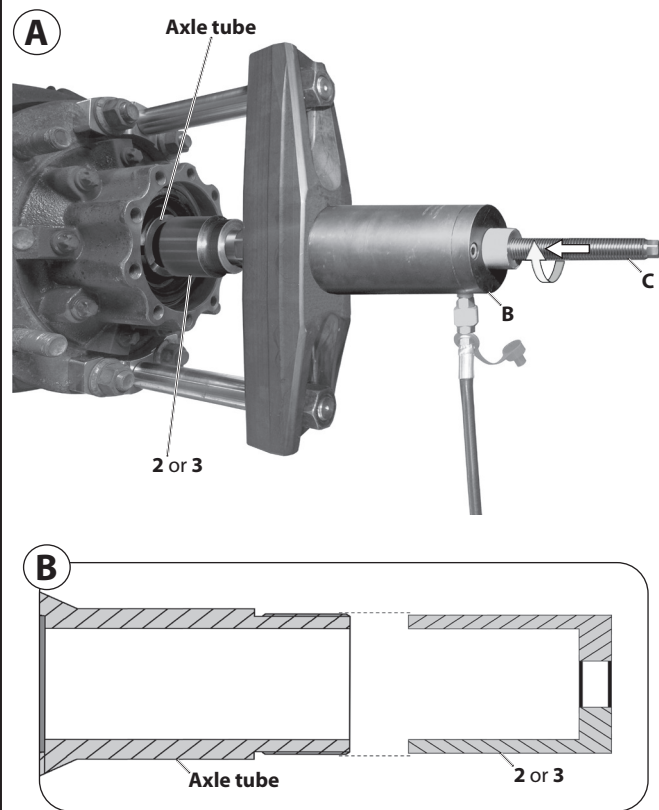

**Fig. 10:** Completely remove the wheel hub as a second step.

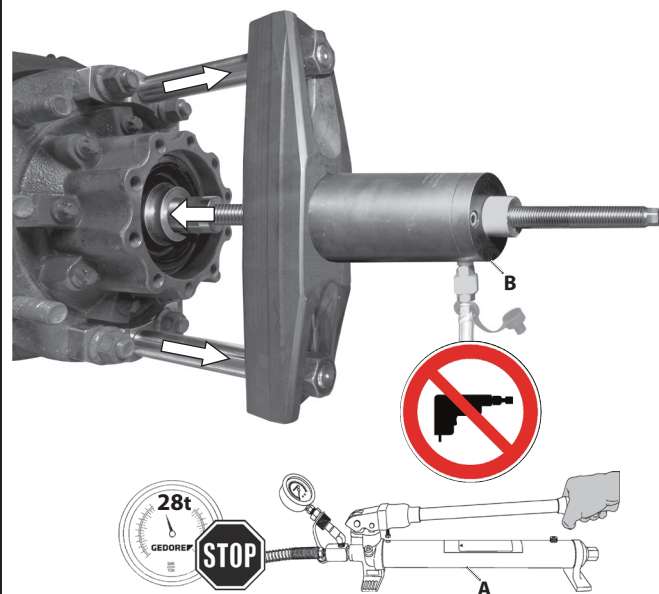

**i** Max. stroke of the hydr. cyl. [B] is 50mm!  
As soon as it is reached: Stop pulling off, release the pressure on hydr. pump [A], screw in thrust spindle [C], continue pulling off.

8. Release pressure on hydraulic pump [A].  
If the wheel hub is then...  
...tightly sitting on the axle tube, go on with **Point 9**.  
...already sitting loose on the axle tube, go on with **Point 11**.

**CAUTION**

The axle tube, the wheel hub and the pressure sleeve [2 or 3] may be damaged when pulling off the wheel hub.

- Use the suitable pressure sleeve [2 or 3], which must be in full and secure contact with the axle tube and be smaller than the inner dia. of the wheel hub! (Fig. 9 B)

9. Remove thrust piece [4] on the wheel hub puller.  
Then, screw in the thrust spindle [C] in the hydraulic cylinder [B], until the thrust piece [2 or 3] lies completely and centrally on the axle tube. (Fig. 9 A+B)

**WARNING**

When pulling off wheel hubs, there is a risk of breakage and flinging around, as well as heavy parts falling off, which can lead to **DEATH** and **SEVERE INJURIES**.

- Make sure that the wheel hub puller is **always** secured by 4x wheel bolts on the wheel hub!
- **Always** operate the wheel hub puller manually with muscle power and **never** with a machine!
- **Never** exceed the **maximum load** of 28t!
- **Never** stand in axial extension of the pressure spindle [C].
- Pull off the wheel hub **only** to the extent that it sits loosely on the axle tube.
- **Always** wear your personal protective equipment (safety goggles, protective gloves, safety shoes) when working!

10. Actuate hydraulic pump [A] and pull off the wheel hub **in a second step** to the extent that it sits **loosely** on the axle tube. (Fig. 10)

**WARNING**

The wheel hub puller with the wheel hub can fall down, this may result in **DEATH** or **SERIOUS INJURY**.

- Let the wheel hub on the axle tube and remove the wheel hub puller first!
- Prevent the wheel hub puller and the wheel hub from falling off!
- **Always** wear your personal protective equipment (safety shoes) during work!

11. Loosen the wheel nuts and cautiously remove the wheel hub puller off the wheel hub.

12. Remove the wheel hub off the axle tube according to the manufacturer's instructions.

## Overview of the single parts: KL-1005-100 A

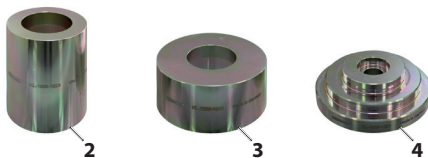
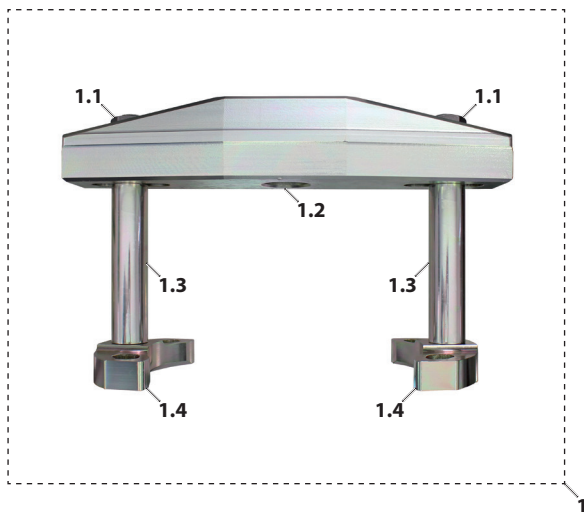

## 5. Care and storage

**CAUTION:** Benzene and chemical solvents can damage plastic parts. After each use, clean all parts with a clean cloth only. To protect them against corrosion, lightly rub all metal parts after use with an anti-corrosion oil or wax that is suitable for tool care. Keep the special tool in a dry and clean place.

## 6. Maintenance and repair

**WARNING:** For safety reasons, ensure that a damaged special tool is no longer used. A professional inspection and repair may only be carried out by specially trained specialist personnel at GEDORE Automotive GmbH. Improper repair of the special tool can result in **DEATH** or **SEVERE INJURIES**.

## 7. Overview of the single parts

### KL-1005-100 A Wheel hub - puller set for commercial vehicles

Item	Part no.	Description	Qty.
1	KL-1005-101 A	Base frame	1
1.1	KL-1005-1014	Hex collar nut M22	2
1.2	KL-1005-1011	Base plate 2¾"-16 UN	1
1.3	KL-1005-1013	Pull rod M22	2
1.4	KL-1005-1012 A	Base M22	2
2	KL-1005-1023	Pressure sleeve long 73 / 59mm dia.	1
3	KL-1005-1022	Pressure sleeve short 103 / 90mm dia.	1
4	KL-1005-1021	Thrust piece	1

## 8. Environmentally compliant disposal

Dispose of special tool and packaging material in accordance with the legal requirements in an environmentally friendly manner.

## 9. Manufacturer's address

**GEDORE Automotive GmbH**  
Breslauer Str. 41 // 78166 Donaueschingen - GERMANY  
Phone: +49 (0)771/83223-71 // E-mail: info.gam@gedore.com