

IRONSIDE 215 HS P

TAV.355/HP/M/IRO
07/06/2006

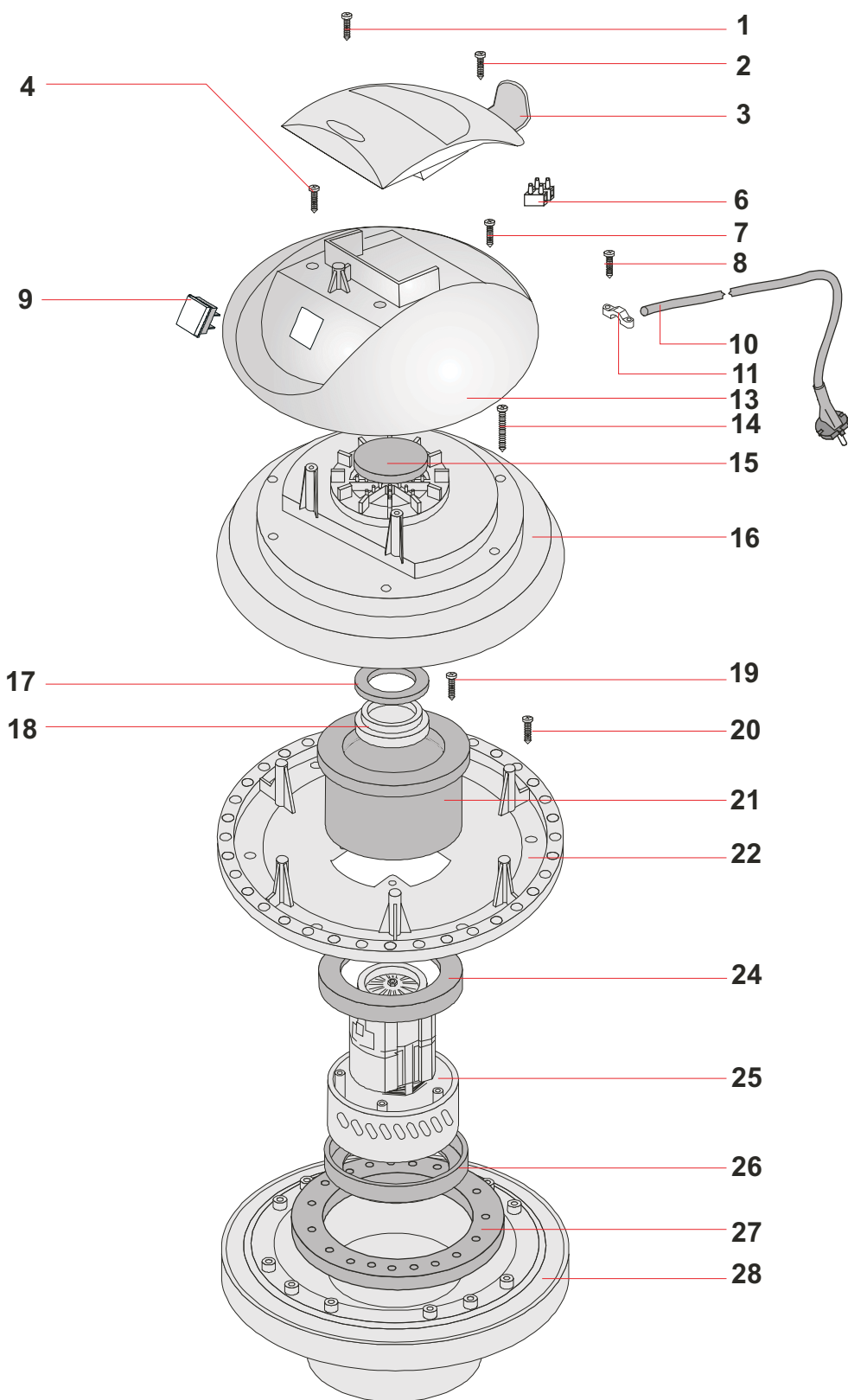

TESTATA YES HP 215/515 M			REF.7193/M IRO
POS.	REF.	DESCRIZIONE	N°
1	1006	VITE PFU TMT PHL 5X20 ZINC. P/R	1
2	1006	VITE PFU TMT PHL 5X20 ZINC. P/R	1
3	6031	MANIGLIA YES	1
4	1006	VITE PFU TMT PHL 5X20 ZINC. P/R	2
6	3464	MORSETT. 300/500 EU/NEV RAD	1
7	1006	VITE PFU TMT PHL 5X20 ZINC. P/R	2
8	1006	VITE PFU TMT PHL 5X20 ZINC. P/R	2
9	326	INTERUTTORE ANTISPRUZZO	1
10	3536	CAVO ELETTRICO 2X1 MT.5	1
11	139	BLOCCACAVO	1
13	7197	COPERCHIO YES HP	1
14	1050	VITE PAT TMT PHL 5X35 ZINC.	6
15	3937	FILTRO MTP/65 H=15 Ø 95	1
16	6035	COPERTURA YES	1
17	3969	RONDELLA H=8 Ø 85 X 65	1
18	311	ANELLO MOTORE H=20 PLAST.	1
19	1979	VITE PFU TMT PHL 5X25 ZINC. P/R	4
20	1006	VITE PFU TMT PHL 5X20 ZINC. P/R	6
21	3900	FILTRO MTP/65 Ø160-120 H=88	1
22	6037	FERMAMOTORE YES	1
24	3901	GUARNIZIONE AL S/F H=5,5	1
25	6230	MOT.BS252 1000W 220-240 50/60 MONO	1
26	7711	GUARNIZIONE AL S/F H=16	1
27	3866	RONDELLA MTP/65 MM18 Ø230X145	1
28	3190 G	BASAMENTO 500 MONOSTADIO C/GUARN.	1
*	7632	KIT ELETTR. 40CM MOTORE	1
*	1101	CAVETTO COLLEGAMENTO	2
*	1106	FASCETTA	3
*	1103	FASTON	2

KIT FILTRANTE YES COMPL. REF.6052			
POS.	REF.	DESCRIZIONE	N°
1	3706	BUSSOLA Ø 8 PLAST	4
2	3724	VITE PAT TMT PHL 5X25 INOX	4
3	2823	CORPO ANTISCHIUMA 99 ALTO	1
4	2676	GALLEGGIANTE 99 ALTO	1
5	507	ANELLO PORTAFILTRO SERIE 500	1
6	2862	FILTRO POLYESTERE 300 CONICO BASSO	1
7	2861	CESTELLO 300 CONICO BASSO	1

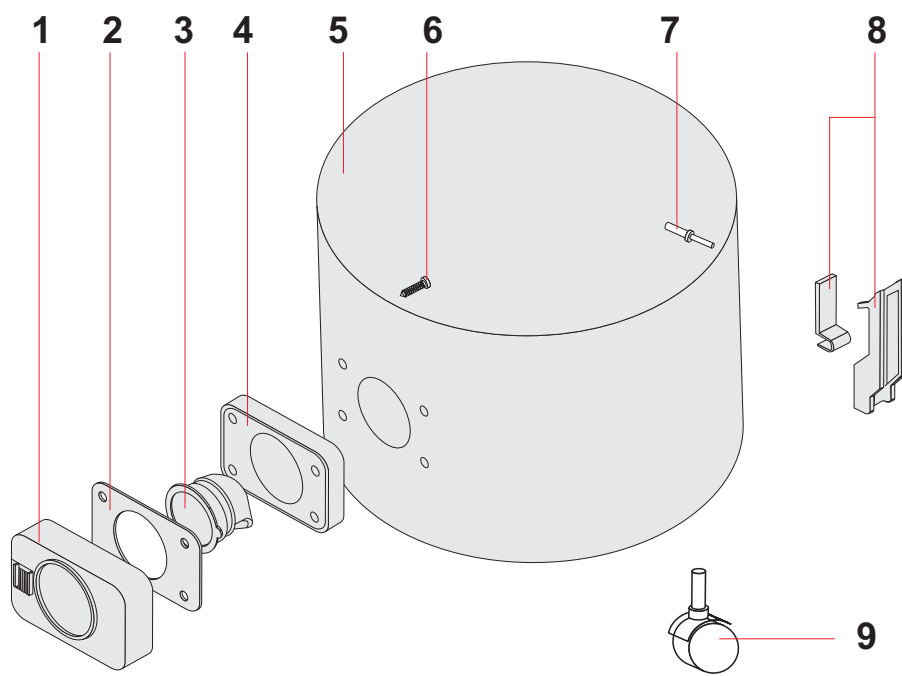
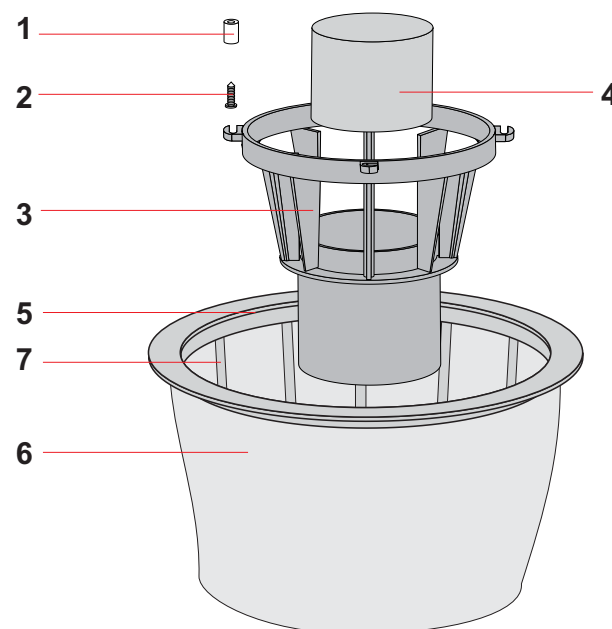

FUSTO PLAST. YES 215 C/RUOTE COMP REF.6041 C/R			
POS.	REF.	DESCRIZIONE	N°
1	2652 A	BOCCHETTONE R 155	1
2	2846	GUARNIZIONE Ø 38	1
3	2593	DEFLETTORE 99	1
4	2586	GUARNIZIONE R 205	1
5	6039	FUSTO PLAST.YES 215	1
6	1026	VITE PAT TMT PHL 5X30 ZINC.	4
7	1302	RIVETTO 5X19	4
8	3602	GANCIO A SCATTO COMPLETO	2
9	6711	RUOTA D.42 C/PERNO	4