



Stehle



Cirkelzaagbladen Catalogus

CZBC 2024_{op} kleur

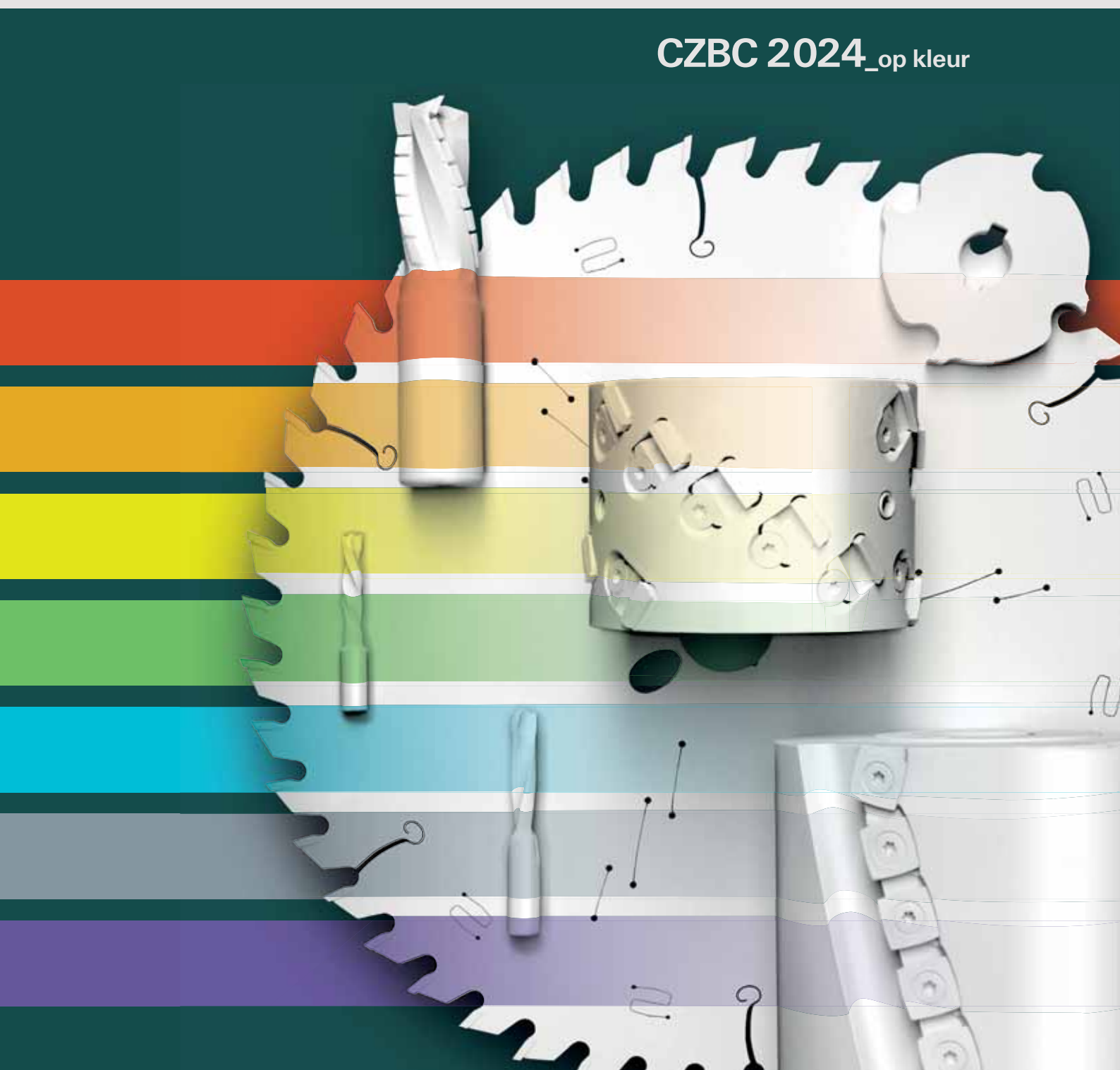



WAAROM STEHLE

Stehle is betrouwbaar

Al meer dan 100 jaar levert Stehle technisch perfecte machinegereedschappen aan de professionele vakhandel. Stehle staat bekend om de zeer nauwkeurige en economische gereedschappen van zeer hoge kwaliteit voor de be- en verwerking van massief hout.

Stehle - een kwaliteitsproduct met een duidelijke handelsvisie

Een optimale prijs-kwaliteitsverhouding. Een hoogwaardig stuk gereedschap. Achter het merk Stehle schuilt wereldwijd een professioneel verkoop- en productie-netwerk. Stehle levert uitsluitend aan de vakhandel.

Stehle - de optimale partner voor de handel

Wij hebben veel artikelen voor u op voorraad. Daarnaast kunnen vele gereedschappen welke niet in de catalogus staan, vaak toch geleverd worden, omdat niet alles in de catalogus opgenomen is. Tevens zijn gereedschappen op maat te produceren.

Stehle - werkt continu aan verbetering

Kwaliteit en continuïteit staan hoog in het vaandel en zullen door de Stehle-groep via ISO-certificatie en verbeteringsprojecten worden gewaarborgd.

Stehle - een goed en uitgebreid programma

Met cirkelzaagbladen, frezen, minizinken, keermessenfrezen, bovenfrezen, boren, CNC, diamant- en handgereedschappen hebben wij een uitgebreid programma. Onze productie- en gereedschapskennis wordt door middel van scholing op hoog niveau gehouden.

Voor gereedschappen die u in deze catalogus niet aantreft, kunt u ten alle tijden contact met ons opnemen. We zijn u bij al uw vragen graag van dienst!

Uw Stehle-Team





Catalogus gesorteerd op kleur/gebruik

		MACHINE	PROGRAMMA	PAGINA	
ABRASIEF	ZAGEN	Handcirkelzagen	HKS - DS - Abrasief	1	
			HKS - LR	2	
			HKS - L	3	
			HKS - L2	4	
BOUW	ZAGEN	Handcirkelzagen/ Tafelcirkelzagen	BKS (NAIL)	5	
			BKS (Gasbeton)	6	
			BKS (Haakse slijper)	6	
HOOUT	ZAGEN	Handcirkelzagen	HKS - DS - Massief	7-8	
			HKS - DS - K + G negatief	8	
			HKS - Massief	9	
			HKS - Board	10	
			K + G negatief	11	
			ZFL	12	
			ZWZ	13	
		ZW	14		
		ZQW	15		
		ZWS	16		
		ZWS-1	17		
		Optimiering-/afkortzagen	OKW / Planet	18	
		Meerbladzagen/4-zijdige	LWR	19	
PLAAT	ZAGEN	Handcirkelzagen Tafelcirkelzagen Formaatzagen	HKS - nn-System DP flex	20	
			Matador 5	21	
			TRF / TRF-1 / HW-zagenset	22-24	
		Voorrits cirkelzagen Platenopdeelzagen	RSK - nn-System	25	
			RSK / RSVS / RS2	26-28	
		Voorrits cirkelzagen	KDF - Industry	29-30	
			HRP - nn-System DP flex	31	
			RSK - nn-System DP flex	32	
		Platenopdeelzagen Voorrits cirkelzagen	RSK - nn-System DP flex verstelbaar	33	
			TFP (HW + DP)	34-35	
		Kantenbewerking	RSK - nn-System	36	
RSK / RSK - WS	37-38				
		KKO / KKM / KKE - Kap/kantenverlijm	39-41		
ALU	ZAGEN	Handcirkelzagen	HKS - DS - Parat - negatief	42	
			Parat - negatief	43	
		Tafelcirkelzagen / Kap- en radiaal-cirkelzagen	NE - ALU	(positief/negatief)	44-45
			NE - Profiel 'G7'	(positief/negatief)	46-47
STAAL	ZAGEN	Handcirkelzagen	HKS - DS - Unisteel	48	
			HKS - DS - Mega-Steel	49	
		Tafelcirkelzagen Dry-Cut-machines	Unisteel	50-51	
			Steel	52	
		Cirkelzaagbladen metaalbewerking	Mega-Steel	53	
			DMO-5/HSS	54-55	
KUNSTSTOF	ZAGEN	Handcirkelzagen Tafelcirkelzagen	HKS - DS - KKT - Hard plastic negatief	56	
			KKS - Plastic	57	
		Kap- en radiaal-cirkelzagen	KKT - Hard plastic Trespa®	(positief/negatief)	58-59
			KKT - DP Trespa®	60	
OVERIG	ZAGEN	Toebehoren	Reduceerringen	61-63	

Onze leveringen en transacties geschieden volgens onze algemene voorwaarden, welke te downloaden zijn via onze website: www.stehle.nl

8 ZAAGBLADEN

- DP-zaagbladen kunnen vanwege (in de regel) nauwkeuriger toleranties met een hogere aanvoersnelheid worden gebruikt dan HW-zaagbladen.
- Bij een grotere materiaaldikte: aantal tanden verminderen.
- Meeneemgaten/Spiebanen

	** Meeneemgaten voorb.: 2/10/60
	Combi-Meeneemgaten
	Dubbele spiebaan (DKN)
	Spiebaan (KN)

— Aanbevolen snijsnelheid in m/sec

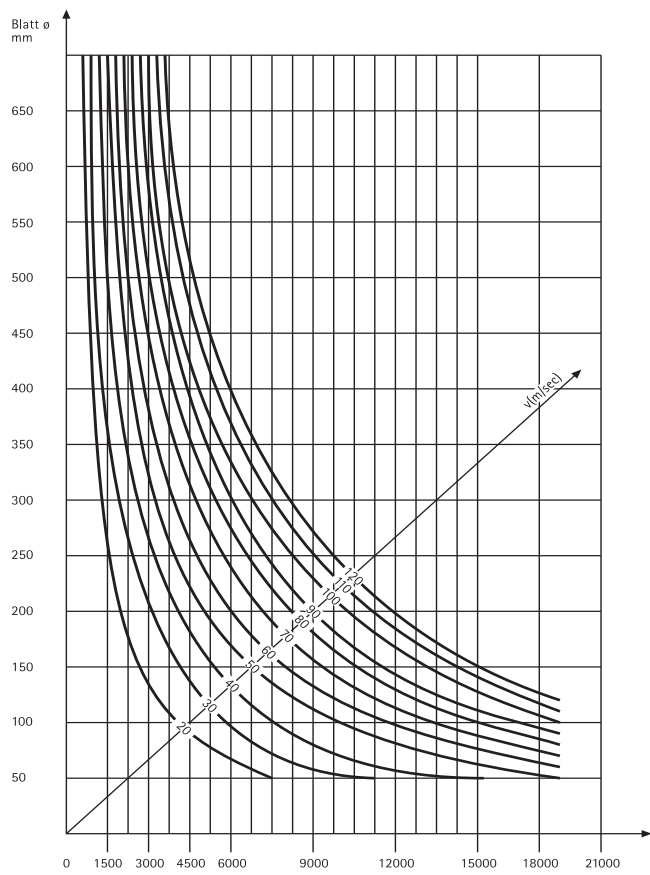

COMBI1

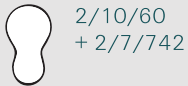

COMBI2

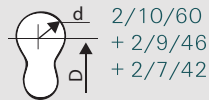

COMBI3

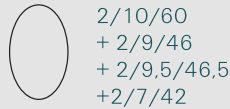

COMBI4

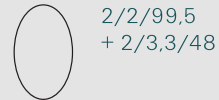

COMBI5

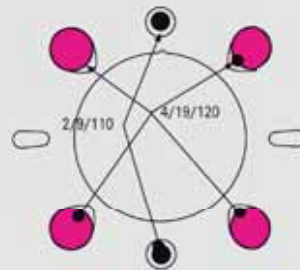
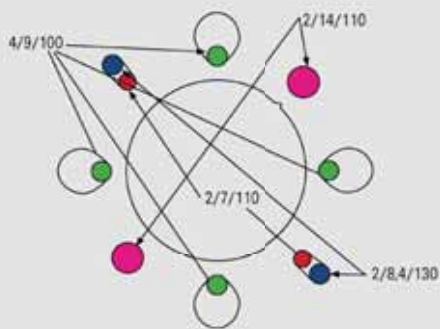

COMBI7

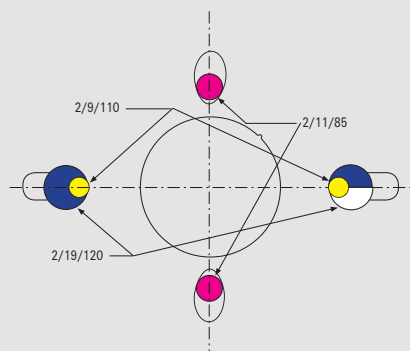
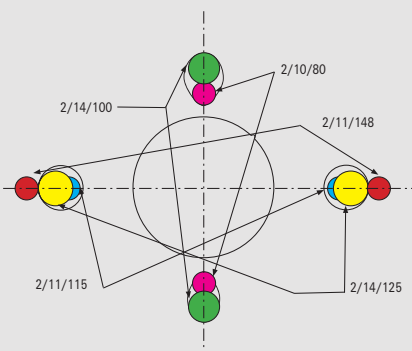

— VERZINKEN VAN MEENEEMGATEN

Voorbeeld: tanden met de klok mee
 Bovenzijde verzonken
 = Links verzonken

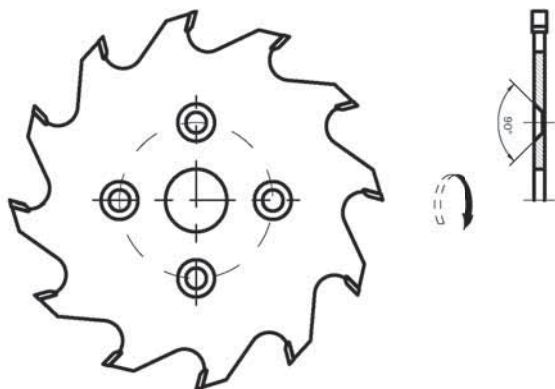

Voorbeeld: tanden tegen de klok in
 Bovenzijde verzonken
 = Rechts verzonken

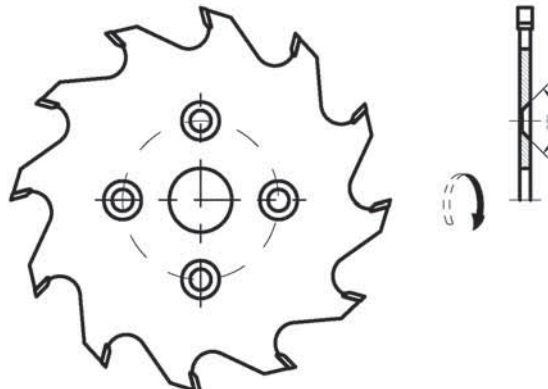

— SPAANHOEK

Negatieve spaanhoek

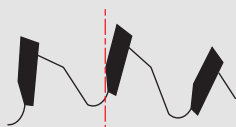

Negatieve spaanhoek: In principe bij afkorten, pendelzagen in hout, materialen op basis van hout, non-ferrometalen en kunststoffen en bij materialen met kans op terugslag bij een goede werkstukopspanning.

Positieve spaanhoek

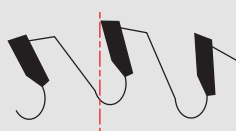

Hoe zachter het materiaal, des te groter de spaanhoek, gewoonlijk 20° bij zacht hout langs-bewerkt, 15° bij hardhout langs-bewerkt, 10° bij plaatmateriaal en schulpen in hout en 8° bij non-ferrometalen en kunststoffen.

— SNIJMATERIAAL

De volgende snijmaterialen worden gebruikt voor de Stehle HW-cirkelzaagbladen:

- Snijmaterialen voor materialen op basis van hout, composietmaterialen en universele toepassing:
 TC03 TC20
 TC04 plus TC25
 TC06
 TC10

- Snijmateriaal voor massief hout:
 TCw15
- Snijmaterialen voor metaalbewerking:
 TCx03
 TCm17



Schulpen
(langs zagen)



Afkorten
(dwars zagen)

— MATERIAALGESCHIKTHEID ZAGEN

MATERIAAL**ABRASIEF**

Minerale materialen op basis van hout (bijv. gipsvezel- cementvezelplaten)



Harde en abrasieve kunststoffen en composietmaterialen

BOUW

Soorten bouwplaatshout

Bekistingsplaten

Hout met spijkers

Met cement vervuild hout en platen

**HOUT**

Schulpen (langs zagen), in hard- en zachthout, nat en droog



Afkorten (dwars zagen) in langvezelige houtsoorten



Afkorten (dwars zagen) in massief hout en materialen op basis van hout

PLATEN

Ruwe spaanplaat

Platen van massief hout, meubelplaat en multiplex

Gefineerde en met papier beklede platen

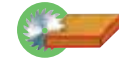

Melamine- en foliebeklede platen

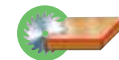

HPL/CPL-beklede platen

Abrasieve composietplaten



Kantfinez op massief hout, fineer- en kunststofranden

ALUMINIUM

Profielen, dunne staalplaat en non-ferro-composietmaterialen

Aluminium en non-ferrometalen

**STAAL**

Formatteren van dunne staalplaat, profielen, non-ferro-metalen en gietijzer



Dunne rvs-plaat, composietmateriaal met rvs-bekleding/staalversterking

KUNSTSTOF

Formateer- en versteksnedes in profielen van duroplast, thermoplast (bijv. acryl, PMMA, PE, PP, ...)



Formaatsnedes in platen van harde en abrasieve kunststoffen en composietmaterialen (bijv. Corian, Trespa®, CFK, GFK, AFK, ...)



Formaatsnedes in Trespa® speciaal



LEGENDE: SQ ▲ geschikt – SQ ▲▲▲ bijzonder geschikt | SW ▲ korte standtijd – SW ▲▲▲ lange standtijd | RS ritszaag

TANDVORMEN

F



F-FA



F



WS



WSA



HR

Hoofdzagen: **WS** [SQ ▲▲ | SW ▲▲ met RS], **WSA** [SQ ▲▲▲▲ | SW ▲▲▲▲]

F-WS-WS [SQ ▲▲▲▲ | SW ▲▲ met / zonder RS]

TR-F-F DU [SQ ▲▲▲▲ | SW ▲▲ met / zonder RS]

HR [SQ ▲▲▲▲ | SW ▲▲▲▲ mit / zonder RS]

Ritszagen: **WS** [SQ ▲▲ | SW ▲▲]

F [SQ ▲▲ | SW ▲▲▲▲]

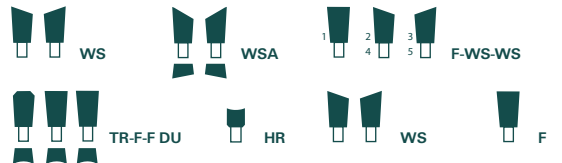

Hoofdzagen: **TR-F** [SQ ▲▲ | SW ▲▲ met RS]

DA-F DU [SQ ▲▲▲▲ | SW ▲▲ met / zonder RS]

HR [SQ ▲▲▲▲ | SW ▲▲▲▲ met / zonder RS]

Ritszagen: **F** [SQ ▲▲ | SW ▲▲], **KO-F** [SQ ▲▲ | SW ▲▲▲▲]

F [SQ ▲▲ | SW ▲▲]

F-WS-WS [SQ ▲▲▲▲ | SW ▲▲]

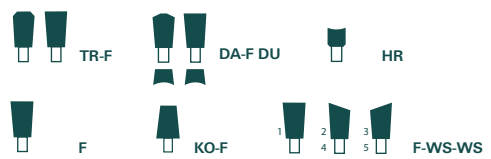

Hoofdzagen: **TR-F** [SQ ▲▲ | SW ▲▲ met RS]

DA-F-FA DU [SQ ▲▲▲▲ | SW ▲▲▲▲ met / zonder RS]

HR [SQ ▲▲▲▲ | SW ▲▲▲▲ met / zonder RS]

Ritszagen: **F** [SQ ▲▲ | SW ▲▲], **KO-F** [SQ ▲▲▲▲ | SW ▲▲]

F [SQ ▲▲ | SW ▲▲]



Afkortzagen: **WS** [SQ ▲▲ | SW ▲▲], **ES** [SQ ▲▲▲▲ | SW ▲▲]

DA-F [SQ ▲▲ | SW ▲▲▲▲]



TR-F



TR-F



F-WFA



WS-FA



TR-F-FA



F-FA



— KWALITEITSNIVEAU ZAGEN

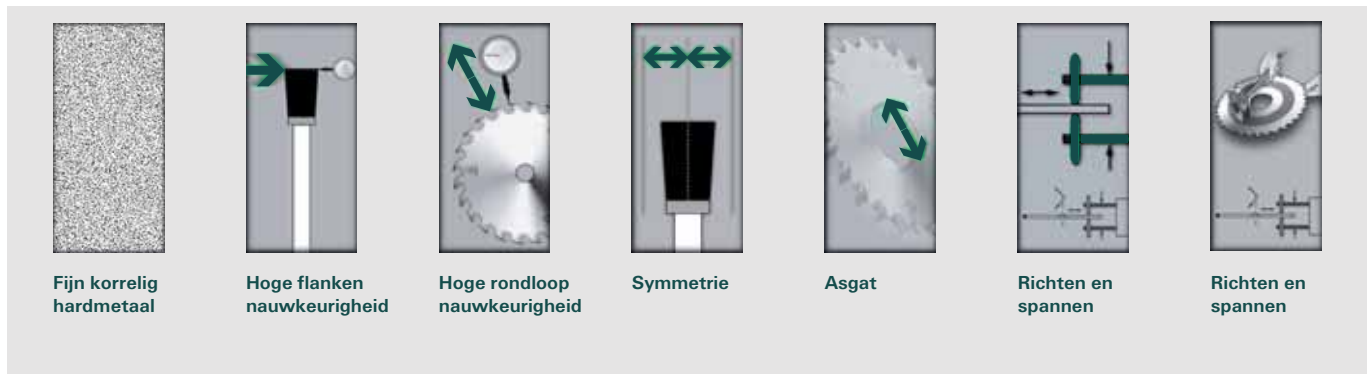

• **Kwaliteitsniveau 1-0-1**

De standaardkwaliteit speciaal voor handcirkelzagen

- ▶ Kop lasergesneden
- ▶ Optimaal snijmateriaal voor de betreffende toepassing
- ▶ Nauwkeurige fabricagetoleranties
- ▶ Ruim formaat hardmetaalmees voor vaak naslijpen. Machinaal gecontroleerd richten en opspannen

• **Kwaliteitsniveau 2-0-6**

De standaardkwaliteit voor tafel-, afkort- en verstekmachines met een uitstekende prijs-prestatieverhouding.

- ▶ Kop lasergesneden
- ▶ Toepassingspecifiek gebruikt hardmetaal
- ▶ Nauwe fabricagetoleranties
- ▶ Hoge vlak- en rondloopnauwkeurigheid
- ▶ Toepassinggerelateerde stillere uitvoering
- ▶ Machinaal gecontroleerd richten en opspannen

• **Kwaliteitsniveau 3-0-1**

Het hoogste kwaliteitsniveau speciaal voor industriële toepassingen op stationaire machines.

- ▶ Kop lasergesneden
- ▶ Toepassingspecifiek gebruikt zeer fijnkorrelig hardmetaal
- ▶ Buitengewoon nauwe fabricagetoleranties
- ▶ Hoogste vlak- en rondloopnauwkeurigheid
- ▶ Stillere uitvoering
- ▶ Handmatig en machinaal gecontroleerd richten en opspannen

* **Snijkwaliteit** ▲ Zeer grove snede, ▲▲ Grove snede, ▲▲▲ Fijne snede, ▲▲▲▲ Zeer fijne snede

** **Extra gaten: Combi1** komt overeen met 2/10/60 + 2/7/42 **Combi2** komt overeen met 2/7/42 + 2/9/46 en 2/10/60 **Combi3** = 2/10/60 + 2/9/46 + 2/9,5/46,5 + 2/7/42 **Combi5** = 2/7/110 + 2/9/110 + 2/8,4/130 + 2/14/110 + 4/9/100 + 4/19/120 **Combi7** = 2/9/110 + 2/10/80 + 2/11/85 + 2/11/115 + 2/11/148 + 2/14/100 + 2/14/125 + 2/19/120

Geschikte **reduceerringen** vindt u aan het einde van deze catalogus

DP

HKS - DS - Handcirkelzaagbladen

Handcirkelzaagbladen DP - vlakland, geschikt voor accumachines en netsnoer machines

Product

Tekening

Machine

Toepassing

Uitvoering

1-0-1

F

- | | | | |
|---|--|---|---|
| <p>Machine / gebruiksaanwijzing</p> <ul style="list-style-type: none"> Handcirkelzagen Voor zaagsneden in cementgebonden plaatmaterialen | <p>Uitvoering</p> <ul style="list-style-type: none"> Tandvorm: vlakland 'F' Snijmateriaal: DP Stamblad gecoat "DS" - Dünnschnitt (B=smal) | <p>Voordelen</p> <ul style="list-style-type: none"> Geringere vermogensopname door gereduceerde snijbreedte | <p>Informatie - Tip</p> <ul style="list-style-type: none"> Niet te gebruiken voor steen, glas en nagels / spijkers Geschikt voor accumachines en netsnoer machines |
|---|--|---|---|

Producteigenschappen						Bestelinformatie					
Ø D [mm]	B [mm]	b [mm]	Ø d [mm]	Z	Snijkwaliteit*		Spaanhoek [°]		VE [St.]	V	ID - No
136	1,6	1,2	20	4	▲	Dewalt	10		1	O	58460500
160	1,8	1,2	20	6	▲	Makita, Festool, Bosch	10		1	O	58460479
165	1,8	1,2	20	6	▲	Makita, Dewalt, Bosch	10		1	O	58460480
168	1,8	1,2	20	6	▲	Mafell, Festool	6		1	L	50460481

* **Snijkwaliteit** ▲ Zeer grove snede, ▲▲ Grove snede, ▲▲▲ Fijne snede, ▲▲▲▲ Zeer fijne snede
 ** **Extra gaten:** Combi1 komt overeen met 2/10/60 + 2/7/42 Combi2 komt overeen met 2/7/42 + 2/9/46 en 2/10/60 Combi3 = 2/10/60 + 2/9/46 + 2/9,5/46,5 + 2/7/42 Combi5 = 2/7/110 + 2/9/110 + 2/8,4/130 + 2/14/110 + 4/9/100 + 4/19/120 Combi7 = 2/9/110 + 2/10/80 + 2/11/85 + 2/11/115 + 2/11/148 + 2/14/100 + 2/14/125 + 2/19/120
 Geschikte **reduceerringen** vindt u aan het einde van deze catalogus

DP HKS - LR
Handcirkelzaagbladen DP - vlakland met fase



Product	Tekening	Machine	Toepassing	Uitvoering
				0,0 mm 1,0 mm 2-0-6 F-FA

Machine / gebruiksaanwijzing <ul style="list-style-type: none"> • Handcirkelzaagbladen • Voor zaagsneden in cementgebonden plaatmaterialen 	Uitvoering <ul style="list-style-type: none"> • Tandvorm: vlakland met fase 'F-FA' • Snijmateriaal: DP • Stamblad gecoat 	Voordelen <ul style="list-style-type: none"> • Uitstekende spaanafvoer door grote spaanruimten • Betere verspaning door grote spaanhoek 	Informatie - Tip <ul style="list-style-type: none"> • Niet inzetbaar voor steen, glas en nagels/ spijkers
---	--	--	---

Producteigenschappen					Bestelinformatie					
Ø D [mm]	B [mm]	b [mm]	Ø d [mm]	Z	Snijkwaliteit*	NL**	Spaanhoek [°]	VE [St.]	V	ID - No
160	2,2	1,6	20	4	▲	2/6/32,5	10		1 L	58457997
190	2,2	1,6	30	4	▲▲	2/7/42	10		1 L	58457994
230	2,2	1,6	30	4	▲▲▲	Combi3	10		1 L	58457992

* Snijkwaliteit ▲ Zeer grove snede, ▲▲ Grove snede, ▲▲▲ Fijne snede, ▲▲▲▲ Zeer fijne snede

** Extra gaten: Combi1 komt overeen met 2/10/60 + 2/7/42 Combi2 komt overeen met 2/7/42 + 2/9/46 en 2/10/60 Combi3 = 2/10/60 + 2/9/46 + 2/9,5/46,5 + 2/7/42 Combi5 = 2/7/110 + 2/9/110 + 2/8,4/130 + 2/14/110 + 4/9/100 + 4/19/120 Combi7 = 2/9/110 + 2/10/80 + 2/11/85 + 2/11/115 + 2/11/148 + 2/14/100 + 2/14/125 + 2/19/120

Geschikte reduceerringen vindt u aan het einde van deze catalogus

DP

HKS - L
 Handcirkelzaagbladen DP - vlakland met fase

Product

Tekening

Machine

Toepassing

Uitvoering

1,0 mm

1-0-1

2-0-6

F-FA

- | | | | |
|--|---|---|--|
| <p>Machine / gebruiksaanwijzing</p> <ul style="list-style-type: none"> Handcirkelzaagbladen Voor door- en bijzagen van laminaat, MDF, spaanplaat, cementgebonden platen, Corian®, Duroplast, gipsplaten en Melamine | <p>Uitvoering</p> <ul style="list-style-type: none"> Tandvorm: vlakland met fase 'F-FA' Snijmateriaal: DP Naslijpzone 1,0 mm Stamblad gecoat | <p>Voordelen</p> <ul style="list-style-type: none"> Uitstekende spaanafvoer door grote spaanruimten Betere verspaning door grote spaanhoek | <p>Informatie - Tip</p> <ul style="list-style-type: none"> Laag aantal tanden voor schulpen Hoog aantal tanden voor formaatsneden Niet te gebruiken voor steen, glas en nagels/ spijkers |
|--|---|---|--|

Producteigenschappen							Bestelinformatie			
Ø D [mm]	B [mm]	b [mm]	Ø d [mm]	Z	Snijkwaliteit*	NL**	Spaanhoek [°]	VE [St.]	V	ID - No
120	2,2	1,6	20	6	▲	2/6/32,5	10	●	1	L 58457378
160	2,2	1,6	20	8	▲	2/6/32,5	10	●	1	L 58457379
160	2,2	1,6	20	30	▲▲▲	2/6/32,5	10	●	1	L 58458171
160	2,2	1,6	30	8	▲	2/7/42	10	●	1	o 58457377
190	2,2	1,6	30	8	▲	2/7/42	10	●	1	L 58457357
190	2,2	1,6	30	30	▲▲▲	2/7/42	10	●	1	L 58457546
210	2,2	1,6	30	12	▲	Combi3	10	●	1	L 58457358
216	2,2	1,6	30	12	▲	Combi3	10	●	1	L 58458137
230	2,2	1,6	30	15	▲	Combi3	10	●	1	L 58457359
250	2,2	1,6	30	16	▲	Combi3	10	●	1	L 58457360
250	2,2	1,6	30	40	▲▲▲	Combi3	10	●	1	o 58458000
300	2,2	1,6	30	36	▲	Combi3	10	●	1	L 58457557

* **Snijkwaliteit** ▲ Zeer grove snede, ▲▲ Grove snede, ▲▲▲ Fijne snede, ▲▲▲▲ Zeer fijne snede
 ** **Extra gaten:** Combi1 komt overeen met 2/10/60 + 2/7/42 Combi2 komt overeen met 2/7/42 + 2/9/46 en 2/10/60 Combi3 = 2/10/60 + 2/9/46 + 2/9,5/46,5 + 2/7/42 Combi5 = 2/7/110 + 2/9/110 + 2/8,4/130 + 2/14/110 + 4/9/100 + 4/19/120 Combi7 = 2/9/110 + 2/10/80 + 2/11/85 + 2/11/115 + 2/11/148 + 2/14/100 + 2/14/125 + 2/19/120
 Geschikte **reduceerringen** vindt u aan het einde van deze catalogus

DP HKS - L2
Formaat en handcirkelzaagbladen DP - vlakland met fase



Product	Tekening	Machine	Toepassing	Uitvoering
				 2,5 mm 2-0-6 3-0-1 F-FA

- | | | | |
|---|---|---|---|
| Machine / gebruiksaanwijzing
• Handcirkelzaagbladen
• Voor formaatsneden in laminaat, MDF, spaanplaat, cementgebonden platen, Corian®, Duroplast, gipsplaten en Melamine | Uitvoering
• Tandvorm: vlakland met fase 'F-FA'
• Snijmateriaal: DP
• Naslijpzone 2,5 mm
• Stamblad gecoat | Voordelen
• Uitstekende spaanafvoer door grote spaanruimte
• Stabiele uitvoering | Informatie - Tip
• Laag aantal tanden voor schulpen
• Hoog aantal tanden voor formaatsneden
• Niet inzetbaar voor steen, glas en nagels/ spijkers |
|---|---|---|---|





Producteigenschappen						Bestelinformatie				
Ø D [mm]	B [mm]	b [mm]	Ø d [mm]	Z	Snijkwaliteit*	NL**	Spaanhoek [°]	VE [St.]	V	ID - No
160	2,4	1,8	20	4	▲	2/6/32,5	8	1	O	58458790
180	2,6	2,0	30	4	▲	2/7/42	8	1	O	58458799
190	2,6	2,2	20	4	▲	Fast-Fix	8	1	O	58458800
190	3,0	2,2	30	4	▲	2/7/42	8	1	O	58458791
216	2,8	2,0	30	4	▲	Combi3	8	1	O	58458792
230	3,0	2,2	30	6	▲▲	Combi3	8	1	O	58458793
250	3,0	2,2	30	6	▲▲	Combi3	8	1	O	58458794
260	2,5	1,8	30	8	▲▲	Combi3	8	1	O	58458797
303	3,0	2,2	30	8	▲▲	Combi3	5	1	O	58458795
315	3,0	2,2	30	10	▲▲	Combi3	8	1	O	58458801
350	3,4	2,4	30	12	▲▲	Combi3	8	1	O	58458802
400	3,4	2,4	30	15	▲▲▲	Combi3	8	1	O	58458798

* **Snijkwaliteit** ▲ Zeer grove snede, ▲▲ Grove snede, ▲▲▲ Fijne snede, ▲▲▲▲ Zeer fijne snede
 ** **Extra gaten:** Combi1 komt overeen met 2/10/60 + 2/7/42 Combi2 komt overeen met 2/7/42 + 2/9/46 en 2/10/60 Combi3 = 2/10/60 + 2/9/46 + 2/9,5/46,5 + 2/7/42 Combi5 = 2/7/110 + 2/9/110 + 2/8,4/130 + 2/14/110 + 4/9/100 + 4/19/120 Combi7 = 2/9/110 + 2/10/80 + 2/11/85 + 2/11/115 + 2/11/148 + 2/14/100 + 2/14/125 + 2/19/120
 Geschikte **reduceerringen** vindt u aan het einde van deze catalogus

HW

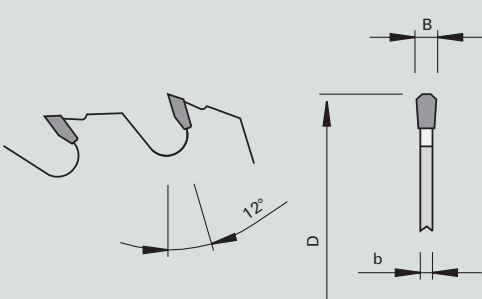
BKS (NAIL)

Bouw/ Nail zaagbladen HW - vlakland met tweezijdige fase

Product	Tekening	Machine	Toepassing	Uitvoering
			  	2-0-6 HW TC20 F-FA

<p>Machine / gebruiksaanwijzing</p> <ul style="list-style-type: none"> Tafelzaagmachines (bouwplaats) Handcirkelzaagbladen Kap- en radiaalcirkelzagen Voor zaagsneden in massief hout en houtbevattende plaatmaterialen 	<p>Uitvoering</p> <ul style="list-style-type: none"> Tandvorm: vlakland met tweezijdige fase "F-FA" Tandbezetting: HW TC20 	<p>Voordelen</p> <ul style="list-style-type: none"> Voor probleemloos doorzagen van hout met vastzittende nagels, spijkers of nieten 	<p>Informatie - Tip</p> <ul style="list-style-type: none"> Asgat vergroten tegen meerprijs mogelijk tot Ø 50 mm bij Kap- en radiaalcirkelzagen goed ingespannen werkstuk in acht nemen
---	--	---	--

Producteigenschappen								Bestelinformatie			
Ø D [mm]	B [mm]	b [mm]	Ø d [mm]	Z	Snijkwaliteit*	NL**	Spaanhoek [°]	VE [St.]	V	ID - No	
160	3,0	2,0	20	12	▲		12	●●●	1	L 68000714	
190	3,0	2,0	30	14	▲	2/7/42	12	●●●	1	L 58112011	
210	3,2	2,2	30	14	▲	2/7/42	12	●●●	1	O 50112013	
235	2,8	1,8	30	16	▲	Combi3	12	●●●	1	L 58112015	
250	3,2	2,2	30	16	▲	Combi3	12	●●●	1	L 58120220	
300	3,2	2,2	30	20	▲	Combi3	12	●●●	1	L 58120041	
315	3,2	2,2	30	20	▲	Combi3	12	●●●	1	L 58120046	
350	3,5	2,5	30	24	▲	Combi3	12	●●●	1	L 58120042	
400	3,5	2,5	30	28	▲	Combi3	12	●●●	1	L 58120043	
450	3,8	2,8	30	30	▲	Combi3	12	●●●	1	L 58120044	
500	3,8	2,8	30	34	▲	Combi3	12	●●●	1	L 58120045	
600	4,4	3,2	30	36	▲	Combi3	12	●●●	1	L 58120227	
700	4,6	3,2	30	42	▲	Combi3	12	●●●	1	L 58120228	



* Snijkwiliteit ▲ Zeer grove snede, ▲▲ Grove snede, ▲▲▲ Fijne snede, ▲▲▲▲ Zeer fijne snede

** Extra gaten: Combi1 komt overeen met 2/10/60 + 2/7/42 Combi2 komt overeen met 2/7/42 + 2/9/46 en 2/10/60 Combi3 = 2/10/60 + 2/9/46 + 2/9,5/46,5 + 2/7/42 Combi5 = 2/7/110 + 2/9/110 + 2/8,4/130 + 2/14/110 + 4/9/100 + 4/19/120 Combi7 = 2/9/110 + 2/10/80 + 2/11/85 + 2/11/115 + 2/11/148 + 2/14/100 + 2/14/125 + 2/19/120

Geschikte reduceerringen vindt u aan het einde van deze catalogus

HW BKS (Gasbeton)

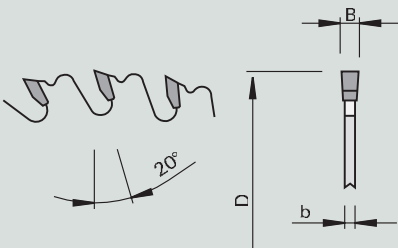
Bouw universeel zaagblad HW - vlakland



Product	Tekening	Machine	Toepassing	Uitvoering
				2-0-6 HW TC06 F

Machine / gebruiksaanwijzing	Uitvoering	Voordelen	Informatie - Tip
<ul style="list-style-type: none"> Tafelcirkelzagen Speciale machines Voor zaagsneden in massief hout Bijzonder geschikt voor gasbetonstenen 	<ul style="list-style-type: none"> Tandvorm: vlakland "F" Tandbezetting: HW TC06 	<ul style="list-style-type: none"> Dit zaagblad is voor meerdere doeleinden te gebruiken Uitstekend geschikt voor gasbetonstenen, gipsplaten en aanverwanten 	<ul style="list-style-type: none"> Asgat vergroten tegen meerprijs mogelijk tot Ø 50 mm

Producteigenschappen								Bestelinformatie			
Ø D [mm]	B [mm]	b [mm]	Ø d [mm]	Z	Snijkwaliteit*	NL**	Spaanhoek [°]	VE [St.]	V	ID - No	
270	3,0	2,0	30	18	▲▲	Combi3	20		1 0	58114170	

HW BKS (Haakse slijper)

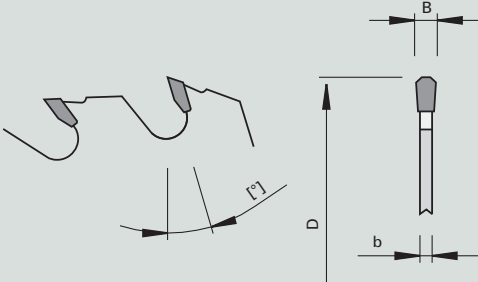
Bouw universeel zaagblad HW - vlakland met tweezijdige fase

Product	Tekening	Machine	Toepassing	Uitvoering
				F-FA 1-0-1 HW TC25

Machine / gebruiksaanwijzing	Uitvoering	Voordelen	Informatie - Tip
<ul style="list-style-type: none"> Haakse slijpmachine (bouwplaats) Voor zaagsneden in allerlei materialen, behalve steen/glas 	<ul style="list-style-type: none"> Tandvorm: vlakland met tweezijdige fase "F-FA" Tandbezetting: HW TC25 MAN uitvoering 	<ul style="list-style-type: none"> Deze zaagbladen zijn uitermate geschikt voor op de haakse slijper uitgevoerd met een beveiligde afschermkap 	<ul style="list-style-type: none"> Deze zaagbladen dienen altijd gecombineerd met een veiligheidskap gebruikt te worden

Producteigenschappen								Bestelinformatie			
Ø D [mm]	B [mm]	b [mm]	Ø d [mm]	Z	Snijkwaliteit*	NL**	Spaanhoek [°]	VE [St.]	V	ID - No	
125	2,0	1,6	25,4	12	▲	MAN	12		1	50105002	

* Snijkwaliteit ▲ Zeer grove snede, ▲▲ Grove snede, ▲▲▲ Fijne snede, ▲▲▲▲ Zeer fijne snede

** Extra gaten: Combi1 komt overeen met 2/10/60 + 2/7/42 Combi2 komt overeen met 2/7/42 + 2/9/46 en 2/10/60 Combi3 = 2/10/60 + 2/9/46 + 2/9,5/46,5 + 2/7/42 Combi5 = 2/7/110 + 2/9/110 + 2/8,4/130 + 2/14/110 + 4/9/100 + 4/19/120 Combi7 = 2/9/110 + 2/10/80 + 2/11/85 + 2/11/115 + 2/11/148 + 2/14/100 + 2/14/125 + 2/19/120

Geschikte reduceerringen vindt u aan het einde van deze catalogus

HW HKS - DS - Massief - Handcirkelzaagbladen

Handcirkelzaagbladen HW - vlakland - wisseltand, geschikt voor accumachines en netsnoer machines



Product



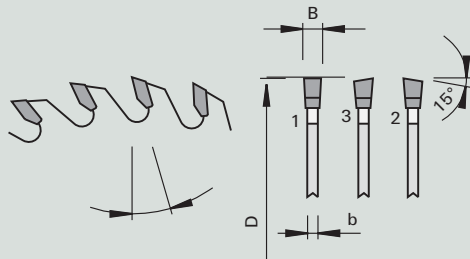

Tekening



Machine

Toepassing

Uitvoering



2-0-6



HW
TC10

F-
WS

<p>Machine / gebruiksaanwijzing</p> <ul style="list-style-type: none"> • Handcirkelzagen • Voor schulpen en afkorten van massief hout 	<p>Uitvoering</p> <ul style="list-style-type: none"> • Tandvorm: vlakland met wisseltand 'F-WS' • Snijmateriaal HW TC10 • "DS" - Dünnschnitt (B=smal) 	<p>Voordelen</p> <ul style="list-style-type: none"> • Geringere vermogensopname door gereduceerde snijbreedte 	<p>Informatie - Tip</p> <ul style="list-style-type: none"> • Geschikt voor accumachines en netsnoer machines
---	--	--	---

Producteigenschappen						Bestelinformatie					
Ø D [mm]	B [mm]	b [mm]	Ø d [mm]	Z	Snijkwaliteit*		Spaanhoek [°]		VE [St.]	V	ID - No
136	1,5	1,0	20	18	▲	Dewalt	20		1	L	58110400
136	1,5	1,0	20	24	▲▲	Dewalt	20		1	L	58110401
160	1,8	1,2	20	18	▲	Mafell, Festool	20		1	L	58110413
160	1,8	1,2	20	24	▲	Makita, Festool, Bosch	15		1	L	58110423
160	1,8	1,2	20	30	▲▲	Mafell, Festool	15		1	L	58110424
160	1,8	1,2	20	48	▲▲▲▲	Mafell, Festool	10		1	L	58110419
165	1,6	1,2	15,88	24	▲▲▲▲	Milwaukee	15		1	O	58110421
165	1,8	1,2	15,88	40	▲▲▲	Milwaukee	10		1	L	58110405
165	1,8	1,2	20	18	▲	Makita, Dewalt, Bosch	20		1	L	58110402
165	1,8	1,2	20	24	▲	Makita, Dewalt, Bosch	15		1	L	58110403
165	1,8	1,2	20	36	▲▲	Makita, Dewalt, Bosch	15		1	L	58110404
165	1,8	1,2	20	48	▲▲▲▲	Makita, Dewalt, Bosch	10		1	L	58110420
168	1,8	1,2	20	18	▲	Mafell, Festool	20		1	L	58110427
168	1,8	1,2	20	30	▲▲▲	Mafell, Festool	15		1	L	58110428
168	1,8	1,2	20	48	▲▲▲▲	Mafell, Festool	10		1	L	58110429
184	1,6	1,1	16	54	▲▲▲	Dewalt	10		1	L	58110406
184	1,8	1,2	20	24	▲▲▲	Mafell	20		1	L	58110416
190	1,8	1,2	20	48	▲▲▲	Dewalt	15		1	L	58110407
190	1,8	1,2	30	24	▲▲▲	Hilti, Milwaukee, Dewalt	20		1	L	58110417
190	1,8	1,2	30	48	▲▲▲▲	Hilti	15		1	O	58110418

* Snijkwiliteit ▲ Zeer grove snede, ▲▲ Grove snede, ▲▲▲ Fijne snede, ▲▲▲▲ Zeer fijne snede

** Extra gaten: Combi1 komt overeen met 2/10/60 + 2/7/42 Combi2 komt overeen met 2/7/42 + 2/9/46 en 2/10/60 Combi3 = 2/10/60 + 2/9/46 + 2/9,5/46,5 + 2/7/42 Combi5 = 2/7/110 + 2/9/110 + 2/8,4/130 + 2/14/110 + 4/9/100 + 4/19/120 Combi7 = 2/9/110 + 2/10/80 + 2/11/85 + 2/11/115 + 2/11/148 + 2/14/100 + 2/14/125 + 2/19/120

Geschikte reduceerringen vindt u aan het einde van deze catalogus

Producteigenschappen						Bestelinformatie					
Ø D [mm]	B [mm]	b [mm]	Ø d [mm]	Z	Snijkwaliteit*		Spaanhoek [°]		VE [St.]	V	ID - No
210	1,8	1,2	30	60	▲▲▲	Dewalt Extrem	15		1	L	58110408
216	2,0	1,4	30	24	▲	Dewalt	20		1	#	58110409
216	2,0	1,4	30	36	▲▲	Dewalt	15		1	L	58110410
216	2,0	1,4	30	60	▲▲▲	Dewalt	10		1	L	58110411
250	2,2	1,6	30	24	▲	Dewalt	20		1	L	58110412

HW HKS - DS - K + G negatief - Handcirkelzaagbladen

Kap- en radiaal cirkelzaagbladen HW - vlakland met wisseltand, geschikt voor accumachines en netsnoer machines

Product



Tekening

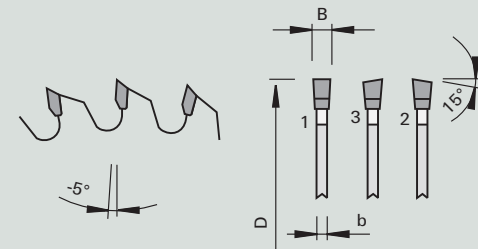

Machine



Toepassing



Uitvoering



2-0-6

HW TC10

F-WS

Machine / gebruiksaanwijzing	Uitvoering	Voordelen	Informatie - Tip
<ul style="list-style-type: none"> • Handcirkelzagen • Kap- en radiaal cirkelzagen • Voor dwarsneden in massief hout en plaatmaterialen 	<ul style="list-style-type: none"> • Tandvorm: vlakland met wisseltand 'F-WS' • Snijmateriaal HW TC10 • "DS" - Dünnschnitt (B=smal) 	<ul style="list-style-type: none"> • Negatieve spaanhoek voor zuivere en mooie snijkwaliteit 	<ul style="list-style-type: none"> • Geschikt voor accumachines en netsnoer machines

Producteigenschappen						Bestelinformatie					
Ø D [mm]	B [mm]	b [mm]	Ø d [mm]	Z	Snijkwaliteit*	NL**	Spaanhoek [°]		VE [St.]	V	ID - No
216	1,8	1,2	30	48	▲▲▲		-5		1	L	58110425
305	2,2	1,6	30	72	▲▲▲		-5		1	L	58110426

* Snijkwaliteit ▲ Zeer grove snede, ▲▲ Grove snede, ▲▲▲ Fijne snede, ▲▲▲▲ Zeer fijne snede
 ** Extra gaten: Combi1 komt overeen met 2/10/60 + 2/7/42 Combi2 komt overeen met 2/7/42 + 2/9/46 en 2/10/60 Combi3 = 2/10/60 + 2/9/46 + 2/9,5/46,5 + 2/7/42 Combi5 = 2/7/110 + 2/9/110 + 2/8,4/130 + 2/14/110 + 4/9/100 + 4/19/120 Combi7 = 2/9/110 + 2/10/80 + 2/11/85 + 2/11/115 + 2/11/148 + 2/14/100 + 2/14/125 + 2/19/120
 Geschikte reduceerringen vindt u aan het einde van deze catalogus

HW

HKS - Massief

Handcirkelzaagbladen HW - wisseltand - schulpen (langs zagen)

Product

Tekening

Machine

Toepassing

Uitvoering

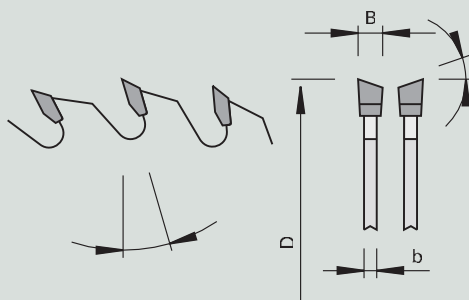

1-0-1

HW
TC10

WS

Machine / gebruiksaanwijzing

- Handcirkelzagen
- Voor schulpen (langs zagen) van massief hout
- Voor afkorten grove snede

Uitvoering

- Tandvorm: wisseltand "WS"
- Tandbezetting: HW TC10

Voordelen

Informatie - Tip

- Grotere maten zie ZQW

Producteigenschappen

Bestelinformatie

Ø D [mm]	B [mm]	b [mm]	Ø d [mm]	Z	Snijkwaliteit*	NL**	Spaanhoek [°]	VE [St.]	V	ID - No
120	1,8	1,3	20	24	▲▲		15	1	L	50104061
125	2,4	1,6	20	20	▲▲	2/5,5/30	15	1	L	50110011
130	2,4	1,6	20	20	▲▲	2/6/32,5	15	1	L	50110017
140	2,4	1,6	20	20	▲▲	2/6/32,5	15	1	L	50110028
150	2,6	1,6	20	12	▲	2/6/32,5	20	1	L	50110243
150	2,6	1,6	20	24	▲▲	2/6/32,5	15	1	L	50110039
160	2,6	1,6	16	24	▲▲	2/6/32,5	15	1	L	50110051
160	2,2	1,6	20	12	▲	2/6/32,5	20	1	L	50110244
160	2,2	1,6	20	24	▲▲	2/6/32,5	15	1	L	50110054
160	2,6	1,6	30	24	▲▲	2/7/42	15	1	L	50110057
165	2,6	1,6	20	24	▲	2/6/32,5	15	1	L	50110060
165	2,6	1,6	30	24	▲	2/7/42	15	1	L	50110130
170	2,6	1,6	30	24	▲▲	2/7/42	20	1	L	50110069
180	2,6	1,6	16	24	▲▲	2/6/32,5	15	1	L	50110081
180	2,6	1,6	20	24	▲▲	2/6/32,5	20	1	L	50110075
180	2,6	1,6	30	14	▲	2/7/42	20	1	L	50110248
180	2,6	1,6	30	24	▲▲	2/7/42	20	1	L	50110078
184	2,6	1,6	20	24	▲▲	2/6/32,5	15	1	O	50110082
190	2,6	1,6	16	24	▲▲	2/6/32,5	15	1	L	50110153
190	2,6	1,6	20	16	▲	2/6/32,5	20	1	O	50110250
190	2,6	1,6	20	24	▲▲	2/6/32,5	15	1	L	50110154
190	2,6	1,6	30	16	▲	2/7/42	20	1	L	50110251
190	2,6	1,6	30	24	▲▲	2/7/42	20	1	L	50110155
190	2,6	1,6	30	24	▲▲		15	1	L	58114105
200	2,8	1,8	30	18	▲	2/7/42	20	1	L	50110252
200	2,8	1,8	30	30	▲▲▲	2/7/42	15	1	L	50110095
205	2,6	1,8	18	30	▲▲▲		15	1	L	50110286
210	2,8	1,8	30	18	▲	2/7/42	20	1	L	50110253
210	2,8	1,8	30	30	▲▲▲	2/7/42	15	1	L	50110104
216	2,8	1,8	30	30	▲▲▲	2/7/42	20	1	L	50110107
220	2,8	1,8	30	24	▲▲	2/7/42	15	1	L	50110164
220	2,8	1,8	30	36	▲▲▲	2/7/42	15	1	L	50110110
225	2,8	1,8	30	24	▲▲	2/7/42	15	1	L	50110165
225	2,8	1,8	30	34	▲▲▲	2/7/42	15	1	L	50110228
230	2,8	1,8	30	18	▲	2/7/42	20	1	L	50110255
230	2,8	1,8	30	24	▲▲	2/7/42	15	1	L	50110168
230	2,8	1,8	30	36	▲▲▲	2/7/42	15	1	L	50110113

* Snij kwaliteit ▲ Zeer grove snede, ▲▲ Grove snede, ▲▲▲ Fijne snede, ▲▲▲▲ Zeer fijne snede

** Extra gaten: Combi1 komt overeen met 2/10/60 + 2/7/42 Combi2 komt overeen met 2/7/42 + 2/9/46 en 2/10/60 Combi3 = 2/10/60 + 2/9/46 + 2/9,5/46,5 + 2/7/42 Combi5 = 2/7/110 + 2/9/110 + 2/8,4/130 + 2/14/110 + 4/9/100 + 4/19/120 Combi7 = 2/9/110 + 2/10/80 + 2/11/85 + 2/11/115 + 2/11/148 + 2/14/100 + 2/14/125 + 2/19/120

Geschikte reduceerringen vindt u aan het einde van deze catalogus

HW HKS - Board

Handcirkelzaagbladen voor afwerksneden HW - wisseltand (afkort)

Product



Tekening

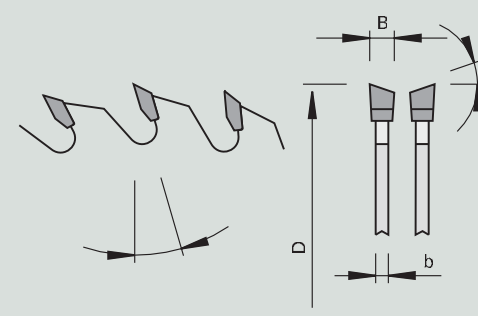

Machine



Toepassing



Uitvoering

1-0-1



HW
TC10

WS

<p>Machine / gebruiksaanwijzing</p> <ul style="list-style-type: none"> • Handcirkelzagen • Kap- en radiaal cirkelzagen • Voor afkorten en formatteren van plaatmateriaal op basis van hout 	<p>Uitvoering</p> <ul style="list-style-type: none"> • Tandvorm: wisseltand 'WS' • Snijmateriaal HW TC10 	<p>Voordelen</p> <ul style="list-style-type: none"> • Zuivere zaagsneden 	<p>Informatie - Tip</p> <ul style="list-style-type: none"> • Grotere maten zie ZWS
---	--	---	---

Producteigenschappen					Bestelinformatie					
Ø D [mm]	B [mm]	b [mm]	Ø d [mm]	Z	Snijkwaliteit*	NL**	Spaanhoek [°]	VE [St.]	V	ID - No
100	2,4	1,4	12	30	▲▲▲		10	1	L	50110001
100	2,4	1,4	22	30	▲▲▲		10	1	L	50110003
105	2,4	1,4	22	30	▲▲▲		10	1	L	50110006
125	2,4	1,6	20	36	▲▲▲	2/6/32,5	10	1	L	50110012
130	2,4	1,6	20	36	▲▲	2/6/32,5	10	1	L	50110018
140	2,4	1,6	20	36	▲▲▲	2/6/32,5	10	1	L	50110029
150	2,6	1,6	20	36	▲▲▲	2/6/32,5	15	1	L	50110040
150	2,6	1,6	20	48	▲▲▲▲	2/6/32,5	10	1	L	50110041
160	2,6	1,6	16	48	▲▲▲▲	2/6/32,5	10	1	L	50110053
160	2,2	1,6	20	36	▲▲▲	2/6/32,5	15	1	L	50110055
160	2,2	1,6	20	48	▲▲▲▲	2/6/32,5	10	1	L	50110056
160	2,2	1,6	20	48 Vario	▲▲▲▲	2/6/32,5	5	1	L	58110356
160	2,6	1,6	30	36	▲▲▲	2/7/42	15	1	L	50110058
160	2,6	1,6	30	48	▲▲▲▲	2/7/42	10	1	L	50110059
165	2,6	1,6	20	36	▲▲▲	2/6/32,5	15	1	L	50110061
165	2,6	1,6	20	48	▲▲▲▲	2/6/32,5	10	1	L	50110062
170	2,6	1,6	30	36	▲▲▲	2/7/42	15	1	L	50110070
170	2,6	1,6	30	48	▲▲▲▲	2/7/42	10	1	L	50110071
180	2,6	1,6	16	48	▲▲▲▲	2/6/32,5	10	1	L	50110183
180	2,6	1,6	20	40	▲▲▲	2/6/32,5	15	1	L	50110076
180	2,6	1,6	30	40	▲▲▲	2/7/42	15	1	L	50110079
180	2,6	1,6	30	54	▲▲▲▲	2/7/42	10	1	L	50110080
184	2,6	1,6	16	40	▲▲▲	2/6/32,5	15	1	L	50110282
190	2,6	1,6	16	30	▲▲▲	2/6/32,5	15	1	L	50110083
190	2,6	1,6	16	42	▲▲▲▲	2/6/32,5	10	1	L	50110084
190	2,6	1,6	20	30	▲▲▲	2/6/32,5	15	1	L	50110086
190	2,6	1,6	20	48	▲▲▲▲	2/6/32,5	10	1	L	50110087
190	2,6	2,0	20FX	32	▲▲▲	Fast-Fix	10	1	L	50110266
190	2,6	2,0	20FX	48	▲▲▲▲	Fast-Fix	10	1	L	50110267
190	2,6	2,0	20FX	60	▲▲▲	Fast-Fix	10	1	L	50110268
190	2,6	1,6	30	30	▲▲▲	2/7/42	15	1	L	50110089
190	2,6	1,6	30	48	▲▲▲▲	2/7/42	10	1	L	50110090
190	2,6	1,6	30	60	▲▲▲▲	2/7/42	10	1	L	50110091
200	2,8	1,8	30	48	▲▲▲▲	2/7/42	15	1	L	50110096
210	2,8	1,8	30	48	▲▲▲▲	2/7/42	15	1	L	50110105
210	2,8	1,8	30	60	▲▲▲▲	2/7/42	10	1	L	50110106
216	2,8	1,8	30	48	▲▲▲▲	2/7/42	15	1	L	50110108
216	2,8	1,8	30	60	▲▲▲▲	2/7/42	10	1	L	50110109
220	2,8	1,8	30	48	▲▲▲▲	2/7/42	15	1	L	50110111

* Snijkwaliteit ▲ Zeer grove snede, ▲▲ Grove snede, ▲▲▲ Fijne snede, ▲▲▲▲ Zeer fijne snede
 ** Extra gaten: Combi1 komt overeen met 2/10/60 + 2/7/42 Combi2 komt overeen met 2/7/42 + 2/9/46 en 2/10/60 Combi3 = 2/10/60 + 2/9/46 + 2/9,5/46,5 + 2/7/42 Combi5 = 2/7/110 + 2/9/110 + 2/8,4/130 + 2/14/110 + 4/9/100 + 4/19/120 Combi7 = 2/9/110 + 2/10/80 + 2/11/85 + 2/11/115 + 2/11/148 + 2/14/100 + 2/14/125 + 2/19/120
 Geschikte reduceerringen vindt u aan het einde van deze catalogus

Producteigenschappen							Bestelinformatie				
Ø D [mm]	B [mm]	b [mm]	Ø d [mm]	Z	Snijkwaliteit*	NL**	Spaanhoek [°]		VE [St.]	V	ID - No
220	2,8	1,8	30	64	▲▲▲▲	2/7/42	10		1	L	50110112
225	2,8	1,8	30	48	▲▲▲▲	2/7/42	10		1	L	50110237
225	2,8	1,8	30	64	▲▲▲▲	2/7/42	10		1	L	50687902
230	2,8	1,8	30	48	▲▲▲▲	2/7/42	15		1	L	50110114
230	2,8	1,8	30	64	▲▲▲▲	2/7/42	10		1	L	50110115

HW K + G negatief

Kap- en radiaalcirkelzaagbladen HW - wisseltand

Product



Tekening

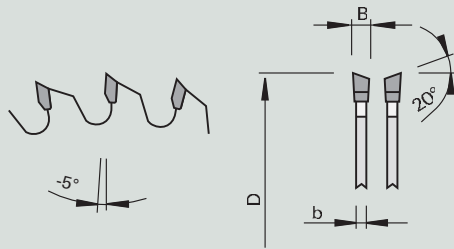

Machine



Toepassing



Uitvoering

2-0-6



HW
TC06

WS

Machine / gebruiksaanwijzing

- Kap- en radiaalcirkelzagen
- Voor dwarsneden in massief hout en plaatmaterialen

Uitvoering

- Tandvorm: wisseltand "WS"
- Tandbezetting: HW TC06

Voordelen

- Negatieve spaanhoek voor zuivere en mooie snijkwaliteit

Informatie - Tip



Producteigenschappen							Bestelinformatie				
Ø D [mm]	B [mm]	b [mm]	Ø d [mm]	Z	Snijkwaliteit*	NL**	Spaanhoek [°]		VE [St.]	V	ID - No
210	2,8	1,8	30	48	▲▲	2/7/42	-5		1	L	58110194
216	2,8	1,8	30	24	▲	2/7/42	-5		1	L	58110180
216	2,8	1,8	30	48	▲▲	2/7/42	-5		1	L	58110181
216	2,8	1,8	30	60	▲▲▲	2/7/42	-5		1	L	58110192
254	3,2	2,2	30	24	▲▲	Combi3	-5		1	L	58118119
254	3,2	2,2	30	40	▲▲	Combi3	-5		1	L	58100218
254	3,2	2,2	30	60	▲▲▲	Combi3	-5		1	L	58100231
254	3,2	2,2	30	80	▲▲▲	Combi3	-5		1	L	58110139
260	2,5	1,8	30	60	▲▲	Combi3	-5		1	L	58100233
260	2,5	1,8	30	80	▲▲▲	Combi3	-5		1	L	58100234
300	3,2	2,2	40	72	▲▲▲	4/12/64 + 2/9/55	-5		1	L	58100237
305	3,2	2,2	30	32	▲	Combi3	-5		1	L	58110270
305	3,2	2,2	30	60	▲▲	Combi3	-5		1	L	58110281
305	3,2	2,2	30	96	▲▲▲	Combi3	-5		1	L	58110272
315	3,2	2,2	30	84	▲▲▲▲	Combi3	-5		1	O	58110274
350	3,2	2,2	40	72	▲▲	4/12/64 + 2/9/55	-5		1	L	58110273
355	3,5	2,5	30	96	▲▲▲	Combi3	-5		1	L	58110143
420	4,4	2,8	40	54	▲▲	4/12/64 + 2/9/55	-5		1	L	58110145
420	3,5	2,5	40	84	▲▲	4/12/64 + 2/9/55	-5		1	L	58110144

* Snijkwaliteit ▲ Zeer grove snede, ▲▲ Grove snede, ▲▲▲ Fijne snede, ▲▲▲▲ Zeer fijne snede
 ** Extra gaten: Combi1 komt overeen met 2/10/60 + 2/7/42 Combi2 komt overeen met 2/7/42 + 2/9/46 en 2/10/60 Combi3 = 2/10/60 + 2/9/46 + 2/9,5/46,5 + 2/7/42 Combi5 = 2/7/110 + 2/9/110 + 2/8,4/130 + 2/14/110 + 4/9/100 + 4/19/120 Combi7 = 2/9/110 + 2/10/80 + 2/11/85 + 2/11/115 + 2/11/148 + 2/14/100 + 2/14/125 + 2/19/120
 Geschikte reduceerringen vindt u aan het einde van deze catalogus

HW

ZFL

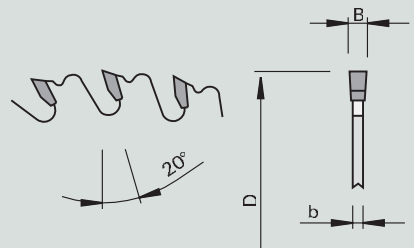
Schulpzaagbladen HW - vlakland

Product	Tekening	Machine	Toepassing	Uitvoering
				2-0-6 HW TC10 F

Machine / gebruiksaanwijzing	Uitvoering	Voordelen	Informatie - Tip
<ul style="list-style-type: none"> Tafelcirkelzagen Speciale machines Voor langszagen in massief hout Bijzonder geschikt voor massief hout met noesten én nat hout 	<ul style="list-style-type: none"> Tandvorm: vlakland "F" Tandbezetting: HW TC10 	<ul style="list-style-type: none"> Geen materiaalluitbreuk door spaanbegrenzing van de tanden 	<ul style="list-style-type: none"> Asgat vergroten tegen meerprijs mogelijk tot Ø 50 mm



Producteigenschappen							Bestelinformatie				
Ø D [mm]	B [mm]	b [mm]	Ø d [mm]	Z	Snijkwaliteit*	NL**	Spaanhoek [°]	VE [St.]	V	ID - No	
250	3,2	2,2	30	18	▲	Combi3	20	☉	1	L	58104050
300	3,2	2,2	30	14	▲	Combi3	20	☉	1	L	58104006
315	3,2	2,2	30	14	▲	Combi3	20	☉	1	L	58104055
350	3,5	2,5	30	16	▲	Combi3	20	☉	1	L	58104015
350	3,5	2,5	30	24	▲	Combi3	20	☉	1	L	58104041
400	3,5	2,5	30	18	▲	Combi3	20	☉	1	L	58104021
450	3,8	2,8	30	32	▲	Combi3	20	☉	1	L	58104051
500	3,8	2,8	30	36	▲	Combi3	20	☉	1	L	58104052
550	4,6	3,2	30	32	▲	Combi3	20	☉	1	L	58104054
600	4,2	3,2	30	40	▲	Combi3	20	☉	1	L	58104048
700	6,0	4,5	30	42	▲	Combi3	20	☉	1	L	58104053
700	4,2	3,2	30	46	▲	Combi3	20	☉	1	L	58104049

* Snijkwaliteit ▲ Zeer grove snede, ▲▲ Grove snede, ▲▲▲ Fijne snede, ▲▲▲▲ Zeer fijne snede

** Extra gaten: Combi1 komt overeen met 2/10/60 + 2/7/42 Combi2 komt overeen met 2/7/42 + 2/9/46 en 2/10/60 Combi3 = 2/10/60 + 2/9/46 + 2/9,5/46,5 + 2/7/42 Combi5 = 2/7/110 + 2/9/110 + 2/8,4/130 + 2/14/110 + 4/9/100 + 4/19/120 Combi7 = 2/9/110 + 2/10/80 + 2/11/85 + 2/11/115 + 2/11/148 + 2/14/100 + 2/14/125 + 2/19/120

Geschikte reduceerringen vindt u aan het einde van deze catalogus

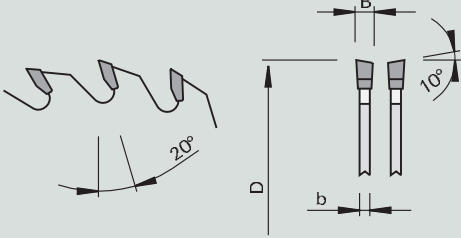
HW **ZWZ**
Schulpzaagblad HW - wisseltand

<p>Product</p> 	<p>Tekening</p> 	<p>Machine</p> 	<p>Toepassing</p>  <p>Uitvoering</p> <p>2-0-6</p> <p>HW TC20</p> <p>WS</p>
--	--	--	---

<p>Machine / gebruiksaanwijzing</p> <ul style="list-style-type: none"> • Tafelcirkelzagen • Speciale machines • Voor schulpen in zacht massief hout • voor het doorzagen, op lengte maken en in verstek zagen van balken, lijmverbindingen en kunststofplaten 	<p>Uitvoering</p> <ul style="list-style-type: none"> • Tandvorm: wisseltand 'WS' • Snijmateriaal HW TC20 	<p>Voordelen</p> <ul style="list-style-type: none"> • Speciaal HW-Kwaliteit voor naaldhout • Extreme tandoverstand voor beter functioneren van het zaagblad 	<p>Informatie - Tip</p> <ul style="list-style-type: none"> • Asgat vergroten tegen meerprijs mogelijk tot Ø 50 mm
---	--	---	--

Producteigenschappen								Bestelinformatie			
Ø D [mm]	B [mm]	b [mm]	Ø d [mm]	Z	Snijkwaliteit*	NL**	Spaanhoek [°]	VE [St.]	V	ID - No	
400	4,4	2,8	30	28	▲	Combi3	20	1	L	58100183	

* Snijkwaliteit ▲ Zeer grove snede, ▲▲ Grove snede, ▲▲▲ Fijne snede, ▲▲▲▲ Zeer fijne snede





** Extra gaten: Combi1 komt overeen met 2/10/60 + 2/7/42 Combi2 komt overeen met 2/7/42 + 2/9/46 en 2/10/60 Combi3 = 2/10/60 + 2/9/46 + 2/9,5/46,5 + 2/7/42 Combi5 = 2/7/110 + 2/9/110 + 2/8,4/130 + 2/14/110 + 4/9/100 + 4/19/120 Combi7 = 2/9/110 + 2/10/80 + 2/11/85 + 2/11/115 + 2/11/148 + 2/14/100 + 2/14/125 + 2/19/120

Geschikte reduceerringen vindt u aan het einde van deze catalogus

HW

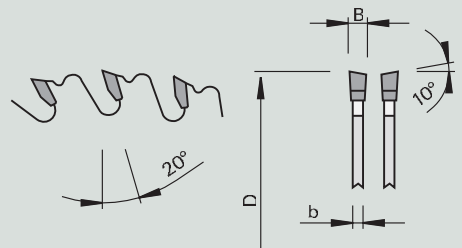
ZW

Schulp- en afkortzaagbladen HW - wisseltand

Product	Tekening	Machine	Toepassing	Uitvoering
		 		2-0-6 HW TC10 WS

Machine / gebruiksaanwijzing	Uitvoering	Voordelen	Informatie - Tip
<ul style="list-style-type: none"> Tafelcirkelzagen Speciale machines Voor zaagsneden in massief hout Bijzonder geschikt voor hout met noesten 	<ul style="list-style-type: none"> Tandvorm: wisseltand "WS" Tandbezetting: HW TC10 	<ul style="list-style-type: none"> Geen materiaalaaluitbreuk door spaanbegrenzing van de tanden 	<ul style="list-style-type: none"> Asgat vergroten tegen meerprijs mogelijk tot Ø 50 mm



Producteigenschappen							Bestelinformatie			
Ø D [mm]	B [mm]	b [mm]	Ø d [mm]	Z	Snijkwaliteit*	NL**	Spaanhoek [°]	VE [St.]	V	ID - No
250	3,2	2,2	30	24	▲	Combi3	20	1	L	58102001
300	3,2	2,2	30	28	▲	Combi3	20	1	L	58102002
315	3,2	2,2	30	28	▲	Combi3	20	1	L	58102003
350	3,5	2,5	30	32	▲	Combi3	20	1	L	58101004
400	3,5	2,5	30	36	▲	Combi3	20	1	L	58101005
450	4,2	2,8	30	20	▲	Combi3	25	1	L	58101020
450	3,8	2,8	30	40	▲	Combi3	20	1	L	58101006
500	3,8	2,8	30	44	▲	Combi3	20	1	L	58102007
600	4,2	3,2	30	54	▲	Combi3	20	1	L	58101018
700	4,2	3,2	30	60	▲	Combi3	20	1	L	58101019

* Snijkwaliteit ▲ Zeer grove snede, ▲▲ Grove snede, ▲▲▲ Fijne snede, ▲▲▲▲ Zeer fijne snede

** Extra gaten: Combi1 komt overeen met 2/10/60 + 2/7/42 Combi2 komt overeen met 2/7/42 + 2/9/46 en 2/10/60 Combi3 = 2/10/60 + 2/9/46 + 2/9,5/46,5 + 2/7/42 Combi5 = 2/7/110 + 2/9/110 + 2/8,4/130 + 2/14/110 + 4/9/100 + 4/19/120 Combi7 = 2/9/110 + 2/10/80 + 2/11/85 + 2/11/115 + 2/11/148 + 2/14/100 + 2/14/125 + 2/19/120

Geschikte reduceerringen vindt u aan het einde van deze catalogus

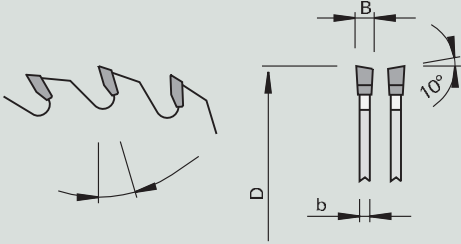
HW ZQW
Schulp- afkortzaagbladen HW - wisseltand

Product	Tekening	Machine	Toepassing	Uitvoering
				2-0-6 HW TC06 HW TC10 WS

Machine / gebruiksaanwijzing	Uitvoering	Voordelen	Informatie - Tip
<ul style="list-style-type: none"> Tafelcirkelzagen Speciale machines Voor formaatsneden in massief hout 	<ul style="list-style-type: none"> Tandvorm: wisseltand 'WS' Snijmateriaal HW TC10/HW TC06 	<ul style="list-style-type: none"> Optimale aanpassing aan de snijkwaliteit, aanvoersnelheid en materiaaldikte door verschillend aantal tanden 	<ul style="list-style-type: none"> Asgat vergroten tegen meerprijs mogelijk tot Ø 50 mm



Producteigenschappen										Bestelinformatie		
Ø D [mm]	B [mm]	b [mm]	Ø d [mm]	Z	Snijkwaliteit*	NL**		Spaanhoek [°]	VE [St.]	V	ID - No	
150	3,2	2,2	30	24	▲	2/7/42		15	1	L	58100096	
180	3,2	2,2	30	30	▲▲	2/7/42		15	1	L	58100016	
200	3,2	2,2	30	34	▲▲	2/7/42		15	1	L	58100017	
235	2,8	1,8	30	18	▲	2/7/42		20	1	L	50110256	
235	2,8	1,8	30	24	▲▲	2/7/42		15	1	L	50110170	
235	3,2	2,2	30	24	▲	Combi3		10	1	L	58100191	
240	2,8	1,8	30	24	▲▲	2/7/42		20	1	L	50110174	
250	3,2	2,2	30	24	▲▲	Combi3		20	1	L	58120060	
250	3,2	2,2	30	30	▲▲	Combi3		20	1	L	58120061	
250	2,8	1,8	30	40	▲▲	Combi3		15	1	L	58120020	
254	2,4	1,8	30	24	▲▲	Combi3	Festool	20	1	L	58120071	
254	2,4	1,8	30	40	▲▲	Combi3	Festool	15	1	L	58120072	
260	3,2	2,2	30	32	▲▲	Combi3		20	1	L	58110185	
270	3,2	2,2	30	24	▲▲	Combi3		20	1	L	58110176	
300	3,2	2,2	30	24	▲	Combi3		20	1	L	58120002	
300	3,2	2,2	30	36	▲	Combi3		20	1	L	58120013	
315	3,2	2,2	30	28	▲	Combi3		20	1	L	58120062	
315	3,2	2,2	30	36	▲	Combi3		20	1	L	58100255	
330	3,2	2,2	30	24	▲	Combi3		25	1	L	58120018	
335	3,2	2,2	30	36	▲	Combi3		20	1	L	58120063	
350	3,5	2,5	30	24	▲	Combi3		20	1	L	58120005	
350	3,5	2,5	30	32	▲▲	Combi3		20	1	L	58100011	
350	3,5	2,5	30	36	▲	Combi3		20	1	L	58120014	
350	3,5	2,5	30	42	▲	Combi3		20	1	L	58120015	
400	3,5	2,5	30	28	▲	Combi3		20	1	L	58100005	
400	3,5	2,5	30	32	▲	Combi3		20	1	L	58120008	
400	3,5	2,5	30	36	▲▲	Combi3		20	1	L	58100012	
400	3,5	2,5	30	48	▲▲	Combi3		20	1	L	58120017	
450	3,8	2,8	30	40	▲▲	Combi3		20	1	L	58100013	
500	3,8	2,8	30	44	▲▲	Combi3		20	1	L	58100014	

* Snijkwaliteit ▲ Zeer grove snede, ▲▲ Grove snede, ▲▲▲ Fijne snede, ▲▲▲▲ Zeer fijne snede
 ** Extra gaten: Combi1 komt overeen met 2/10/60 + 2/7/42 Combi2 komt overeen met 2/7/42 + 2/9/46 en 2/10/60 Combi3 = 2/10/60 + 2/9/46 + 2/9,5/46,5 + 2/7/42 Combi5 = 2/7/110 + 2/9/110 + 2/8,4/130 + 2/14/110 + 4/9/100 + 4/19/120 Combi7 = 2/9/110 + 2/10/80 + 2/11/85 + 2/11/115 + 2/11/148 + 2/14/100 + 2/14/125 + 2/19/120
 Geschikte reduceerringen vindt u aan het einde van deze catalogus

HW

ZWS

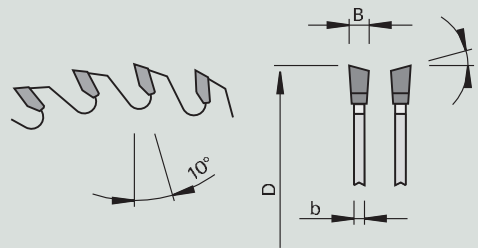
Afkort en zuiversneden zaagbladen HW - wisseltand

Product	Tekening	Machine	Toepassing	Uitvoering
				2-0-6 HW TC06 WS

Machine / gebruiksaanwijzing	Uitvoering	Voordelen	Informatie - Tip
<ul style="list-style-type: none"> Tafelcirkelzagen Speciale machines Voor formaatsneden in massief hout en plaatmaterialen 	<ul style="list-style-type: none"> Tandvorm: wisseltand 'WS' Snijmateriaal HW TC06 	<ul style="list-style-type: none"> Optimale aanpassing aan de snijkwaliteit, aanvoersnelheid en materiaaldikte door verschillend aantal tanden 	<ul style="list-style-type: none"> Asgat vergroten tegen meerprijs mogelijk tot Ø 50 mm

Producteigenschappen										Bestelinformatie			
Ø D [mm]	B [mm]	b [mm]	Ø d [mm]	Z	Snijkwaliteit*	NL**		Spaanhoek [°]	VE [St.]	V	ID - No		
150	3,2	2,2	30	36	▲▲	2/7/42		10	1	L	58100099		
150	3,2	2,2	30	48	▲▲▲	2/7/42		10	1	L	58100101		
180	3,2	2,2	30	54	▲▲▲	2/7/42		10	1	L	58100015		
200	3,2	2,2	30	48	▲▲▲	2/7/42		10	1	L	58100091		
200	3,2	2,2	30	64	▲▲▲	2/7/42		10	1	L	58100025		
235	2,8	1,8	30	36	▲▲▲	2/7/42		15	1	L	50110117		
235	2,8	1,8	30	48	▲▲▲▲	2/7/42		15	1	L	58110121		
235	2,8	1,8	30	64	▲▲▲▲	2/7/42		10	1	L	58110118		
235	3,2	2,2	30	34	▲▲			10	1	O	50100193		
240	2,8	1,8	30	36	▲▲▲	2/7/42		15	1	L	50110123		
240	2,8	1,8	30	48	▲▲▲▲	2/7/42		15	1	L	50110124		
250	3,2	2,2	30	40	▲▲▲	Combi3		10	1	L	58100018		
250	3,2	2,2	30	48	▲▲▲▲	Combi3		10	1	L	58100026		
250	3,2	2,2	30	60	▲▲▲▲	Combi3		10	1	L	58100031		
250	3,2	2,2	30	80	▲▲▲▲	Combi3		10	1	L	58100038		
254	2,4	1,8	30	60	▲▲▲	Combi3	Festool	5	1	L	58120073		
254	3,0	2,2	20/30	40	▲▲▲			10	1	L	58114108		
254	3,2	2,2	30	40	▲▲▲	Combi3		10	1	L	58120067		
254	3,2	2,2	30	60	▲▲▲▲	Combi3		10	1	L	58120068		
260	3,2	2,2	30	40	▲▲▲	Combi3		10	1	L	58110175		
260	3,2	2,2	30	60	▲▲▲▲	Combi3		10	1	L	58100254		
270	3,2	2,2	30	42	▲▲▲	Combi3		10	1	L	58110064		
270	3,2	2,2	30	60	▲▲▲▲	Combi3		10	1	L	58110182		
280	3,2	2,2	30	48	▲▲▲▲	Combi3		10	1	L	58110136		
300	3,2	2,2	30	48	▲	Combi3		10	1	L	58100250		
300	3,2	2,2	30	60	▲▲	Combi3		10	1	L	58100027		
300	3,2	2,2	30	72	▲▲	Combi3		10	1	L	58100032		
300	3,2	2,2	30	96	▲▲▲	Combi3		10	1	L	58100251		
305	3,2	2,2	30	48	▲	Combi3		10	1	L	58120065		
305	3,2	2,2	30	60	▲▲	Combi3		10	1	L	58120066		
315	3,2	2,2	30	48	▲	Combi3		10	1	L	58100252		
315	3,2	2,2	30	60	▲▲	Combi3		10	1	L	58100253		
350	3,5	2,5	30	54	▲▲	Combi3		10	1	L	58100021		
350	3,5	2,5	30	72	▲▲	Combi3		10	1	L	58100028		
350	3,5	2,5	30	84	▲▲	Combi3		10	1	L	58100033		
350	3,5	2,5	30	108	▲▲▲	Combi3		10	1	L	58100040		
400	3,5	2,5	30	60	▲▲	Combi3		10	1	L	58100022		
400	3,5	2,5	30	84	▲▲▲	Combi3		10	1	L	58100029		
400	3,5	2,5	30	96	▲▲▲	Combi3		10	1	L	58100034		

* Snijkwaliteit ▲ Zeer grove snede, ▲▲ Grove snede, ▲▲▲ Fijne snede, ▲▲▲▲ Zeer fijne snede

** Extra gaten: Combi1 komt overeen met 2/10/60 + 2/7/42 Combi2 komt overeen met 2/7/42 + 2/9/46 en 2/10/60 Combi3 = 2/10/60 + 2/9/46 + 2/9,5/46,5 + 2/7/42 Combi5 = 2/7/110 + 2/9/110 + 2/8,4/130 + 2/14/110 + 4/9/100 + 4/19/120 Combi7 = 2/9/110 + 2/10/80 + 2/11/85 + 2/11/115 + 2/11/148 + 2/14/100 + 2/14/125 + 2/19/120

Geschikte reduceerringen vindt u aan het einde van deze catalogus

Producteigenschappen							Bestelinformatie				
Ø D [mm]	B [mm]	b [mm]	Ø d [mm]	Z	Snijkwaliteit*	NL**	Spaanhoek [°]	VE [St.]	V	ID - No	
400	3,5	2,5	30	120	▲▲▲	Combi3	10	1	L	58100041	
450	3,8	2,8	30	66	▲▲	Combi3	10	1	L	58100023	
450	3,8	2,8	30	108	▲▲▲	Combi3	10	1	L	58100060	
500	3,8	2,8	30	72	▲▲	Combi3	10	1	L	58100024	
550	4,0	3,0	30	64	▲	Combi3	10	1	L	58120070	

HW ZWS - 1

Afkort- en formaatzaagbladen HW - wisseltand met ashoek

Product



Tekening

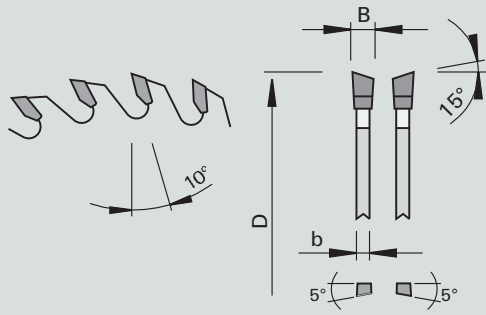

Machine



Toepassing



Uitvoering



Uitvoering: HW TC06

WSA

<p>Machine / gebruiksaanwijzing</p> <ul style="list-style-type: none"> • Tafelcirkelzagen • Speciale machines • Voor formaatsneden in plaatmaterialen 	<p>Uitvoering</p> <ul style="list-style-type: none"> • Tandvorm: wisseltand met ashoek 'WSA' • Snijmateriaal HW TC06 	<p>Voordelen</p> <ul style="list-style-type: none"> • Optimale aanpassing aan snijkwaliteit, aanzetsnelheid en materiaaldikte door verschillende rijen tanden • Verminderde snijdruk door de wisselende ashoek • Lange standtijd zorgen voor de nodige productiviteit en rendabiliteit 	<p>Informatie - Tip</p> <ul style="list-style-type: none"> • Asgat vergroten tegen meerprijs mogelijk tot Ø 50 mm
--	--	---	--





Producteigenschappen							Bestelinformatie				
Ø D [mm]	B [mm]	b [mm]	Ø d [mm]	Z	Snijkwaliteit*	NL**	Spaanhoek [°]	VE [St.]	V	ID - No	
250	3,2	2,2	30	60	▲▲▲	Combi3	10	1	L	58100701	
300	3,2	2,2	30	48	▲▲	Combi3	10	1	L	58100702	
300	3,2	2,2	30	96	▲▲▲▲	Combi3	10	1	L	58100703	
350	3,5	2,5	30	54	▲▲	Combi3	10	1	L	58100704	

* Snijkwaliteit ▲ Zeer grove snede, ▲▲ Grove snede, ▲▲▲ Fijne snede, ▲▲▲▲ Zeer fijne snede

** Extra gaten: Combi1 komt overeen met 2/10/60 + 2/7/42 Combi2 komt overeen met 2/7/42 + 2/9/46 en 2/10/60 Combi3 = 2/10/60 + 2/9/46 + 2/9,5/46,5 + 2/7/42 Combi5 = 2/7/110 + 2/9/110 + 2/8,4/130 + 2/14/110 + 4/9/100 + 4/19/120 Combi7 = 2/9/110 + 2/10/80 + 2/11/85 + 2/11/115 + 2/11/148 + 2/14/100 + 2/14/125 + 2/19/120

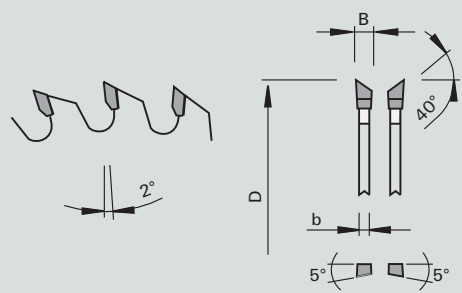
Geschikte reduceerringen vindt u aan het einde van deze catalogus



HW OKW OKW optimalisering-afkortsirkelzaagbladen HW - wisseltand met ashoek

Product	Tekening	Machine	Toepassing	Uitvoering
				3-0-1  HW TC06 WSA

Machine / gebruiksaanwijzing	Uitvoering	Voordelen	Informatie - Tip
<ul style="list-style-type: none"> • Optimalisatie-afkortszaagmachine • Voor dwarssnedes in massief hout 	<ul style="list-style-type: none"> • Spaanhoek positief • Tandvorm: wisseltand met ashoek "WSA" • Snijmateriaal: HW TC 06 • extreem hoge breuktaaiheid en hardheid van de tanden 	<ul style="list-style-type: none"> • verminderde snijdruk door wisselende ashoek, lange standtijden zorgen voor een meest economische, efficiënte productiviteit. 	<ul style="list-style-type: none"> • Andere maten op aanvraag

Producteigenschappen							Bestelinformatie				
Ø D [mm]	B [mm]	b [mm]	Ø d [mm]	Z	Snijkwaliteit*	NL**	Spaanhoek [°]	VE [St.]	V	ID - No	
400	3,4	2,8	30	120	▲▲▲	2/10/60 + 2/12/90 + 2/12/150	2	●	1	L 58807839	
400	4,6	3,5	30	120	▲▲▲	2/10/60	2	●	1	L 189833	
450	4,6	3,5	30	132	▲▲▲	2/15/63	2	●	1	L 189834	
500	4,6	3,5	30	144	▲▲▲	2/15/63	2	●	1	L 58807842	

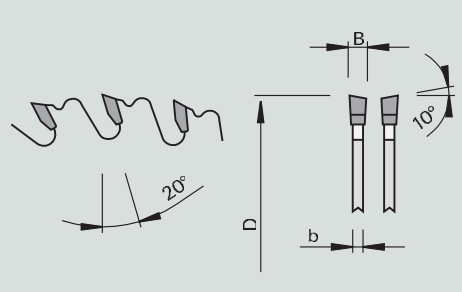
HW Planet Meerblad-cirkelzaagbladen HW - wisseltand met inwendige ruimers

Product	Tekening	Machine	Toepassing	Uitvoering
				3-0-1 HW TC20 WS

Machine / gebruiksaanwijzing	Uitvoering	Voordelen	Informatie - Tip
<ul style="list-style-type: none"> • Tafelcirkelzagen • Langszaagbladen/schulp zaagbladen • Voor langs- en dwarsneden in nat en droog massief hout 	<ul style="list-style-type: none"> • Tandvorm: wisseltand 'WS' • Snijmateriaal HW TC20 • 4 inwendige HW wissers/ruimers 	<ul style="list-style-type: none"> • Geen zijdelings aanlopen van het zaagblad in het hout dmv. HW ruimers/wissers • Uitvoering (spaanbegrensd) zorgt voor een universele inzet 	<ul style="list-style-type: none"> • Geschikt voor manuele aanvoer • Nu met dikker stamblad en grotere snijbreedte



Producteigenschappen							Bestelinformatie				
Ø D [mm]	B [mm]	b [mm]	Ø d [mm]	Z	Snijkwaliteit*	NL**	Santal wissers [St.]	VE [St.]	V	ID - No	
350	3,8	2,5	30	24	▲	Combi2	2+2	●	1	L 50804422	
400	4,2	3,0	30	28	▲	Combi2	2+2	●	1	L 50804423	
450	4,2	3,0	30	36	▲	Combi2	2+2	●	1	L 50804425	

* Snijkwaliteit ▲ Zeer grove snede, ▲▲ Grove snede, ▲▲▲ Fijne snede, ▲▲▲▲ Zeer fijne snede

** Extra gaten: Combi1 komt overeen met 2/10/60 + 2/7/42 Combi2 komt overeen met 2/7/42 + 2/9/46 en 2/10/60 Combi3 = 2/10/60 + 2/9/46 + 2/9,5/46,5 + 2/7/42 Combi5 = 2/7/110 + 2/9/110 + 2/8,4/130 + 2/14/110 + 4/9/100 + 4/19/120 Combi7 = 2/9/110 + 2/10/80 + 2/11/85 + 2/11/115 + 2/11/148 + 2/14/100 + 2/14/125 + 2/19/120

Geschikte reduceerringen vindt u aan het einde van deze catalogus

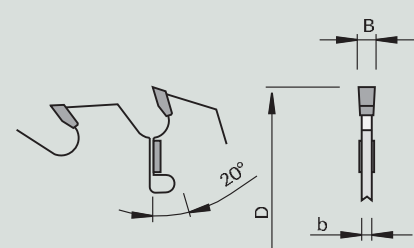
HW LWR
Meerblad-cirkelzaagbladen HW - wisseltand met ruimers

<p>Product</p> 	<p>Tekening</p> 	<p>Machine</p> 	<p>Toepassing</p> 	<p>Uitvoering</p> <p>3-0-1</p> <p>HW TC20</p> <p>F</p>
--	--	--	---	--

<p>Machine / gebruiksaanwijzing</p> <ul style="list-style-type: none"> • Enkel- en dubbel-assige meerblad zaagmachines • Voor schulpen in natte en droge zachte houtsoorten 	<p>Uitvoering</p> <ul style="list-style-type: none"> • Tandvorm: vlakland "F" • Tandbezetting: HW TC20 	<p>Voordelen</p> <ul style="list-style-type: none"> • Geen zijdelings aanlopen van het zaagblad in het hout dmv. HW ruimers/wissers 	<p>Informatie - Tip</p> <ul style="list-style-type: none"> • Voor snijhoogten vanaf 50 mm
---	--	--	--

Producteigenschappen										Bestelinformatie			
Ø D	B	b	Ø d	Z	Ø dmax	max. flens-Ø	Snijkwaa- liteit*	DKN	Santal wissers	VE	V	ID - No	
[mm]	[mm]	[mm]	[mm]		[mm]	[mm]		[mm]	[St.]	[St.]			
250	3,2	2,2	70	20	80	120	▲	2 x 20x5	2+2	☀ 1	L	50457841	
300	3,4	2,2	70	22	90	130	▲	2 x 20x5	2+2	☀ 1	L	50100525	
350	3,6	2,5	70	20	100	140	▲	2 x 20x5	2+2	☀ 1	L	50100528	
350	3,6	2,4	70	28	100	140	▲	2 x 20x5	2+2	☀ 1	L	50457843	
450	4,2	3,0	50	24	100	160	▲		2+2	☀ 1	L	189273	





* Snijkwaa-
liteit ▲ Zeer grove snede, ▲▲ Grove snede, ▲▲▲ Fijne snede, ▲▲▲▲ Zeer fijne snede

** Extra gaten: Combi1 komt overeen met 2/10/60 + 2/7/42 Combi2 komt overeen met 2/7/42 + 2/9/46 en 2/10/60 Combi3 = 2/10/60 + 2/9/46 + 2/9,5/46,5 + 2/7/42 Combi5 = 2/7/110 + 2/9/110 + 2/8,4/130 + 2/14/110 + 4/9/100 + 4/19/120 Combi7 = 2/9/110 + 2/10/80 + 2/11/85 + 2/11/115 + 2/11/148 + 2/14/100 + 2/14/125 + 2/19/120

Geschikte reduceerringen vindt u aan het einde van deze catalogus

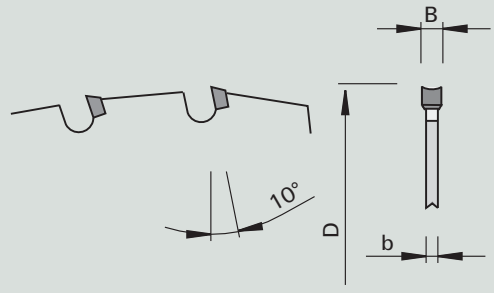
DP **HKS - nn-System DP flex**
Handcirkelzaagbladen DP - hollerugtand



<p>Product</p> 	<p>Tekening</p> 	<p>Machine</p> 	<p>Toepassing</p> 	<p>Uitvoering</p>  <p>NO 2002</p> <p>3-0-1</p> <p>HR</p>
--	--	--	---	---

- | | | | |
|---|--|--|---|
| <p>Machine / gebruiksaanwijzing</p> <ul style="list-style-type: none"> • Handcirkelzaagbladen • Afkortzagen • Voor precisiesnedes in alle gangbare platen op basis van hout en latten • Voor langs- en dwarsnedes in massief hout • Te gebruiken voor diverse materialen zoals gevelplaten | <p>Uitvoering</p> <ul style="list-style-type: none"> • Tandvorm: hollerugtand 'HR' • Snijmateriaal: DP • Speciale snijgeometrie • Kleine spaanruimtes • Stamblad gecoat | <p>Voordelen</p> <ul style="list-style-type: none"> • Hoogste rendabiliteit en productiviteit door extreem lange standtijd • Verminderde snijdruk door holleruggeometrie • Coating beschermt tegen corrosie, hechting van vreemde materialen en vermindert de wrijving bij het stamblad | <p>Informatie - Tip</p> <ul style="list-style-type: none"> • Reinig de nn-systeem DP flex cirkelzaagbladen regelmatig U profiteert van een langdurige, precieze snijkwaliteit en maximaliseert de standtijd van uw innovatieve zaagbladen aanzienlijk. |
|---|--|--|---|

Producteigenschappen							Bestelinformatie				
Ø D [mm]	B [mm]	b [mm]	Ø d [mm]	Z	Snijkwaliteit*	NL**	Spaanhoek [°]		VE [St.]	V	ID - No
160	2,2	1,6	20	20	▲▲▲	2/6/32,5	10		1	L	58459771
160	2,2	1,8	20	30	▲▲▲	2/6/32,5	10		1	L	58459767
190	2,5	2,0	30	36	▲▲▲		10		1	S	58459768
216	2,5	2,0	30	40	▲▲▲		10		1	L	58459769
230	2,5	2,0	30	44	▲▲▲		10		1	S	58459770



* Snijkwaliteit ▲ Zeer grove snede, ▲▲ Grove snede, ▲▲▲ Fijne snede, ▲▲▲▲ Zeer fijne snede

** Extra gaten: Combi1 komt overeen met 2/10/60 + 2/7/42 Combi2 komt overeen met 2/7/42 + 2/9/46 en 2/10/60 Combi3 = 2/10/60 + 2/9/46 + 2/9,5/46,5 + 2/7/42 Combi5 = 2/7/110 + 2/9/110 + 2/8,4/130 + 2/14/110 + 4/9/100 + 4/19/120 Combi7 = 2/9/110 + 2/10/80 + 2/11/85 + 2/11/115 + 2/11/148 + 2/14/100 + 2/14/125 + 2/19/120

Geschikte reduceerringen vindt u aan het einde van deze catalogus

HW Matador 5

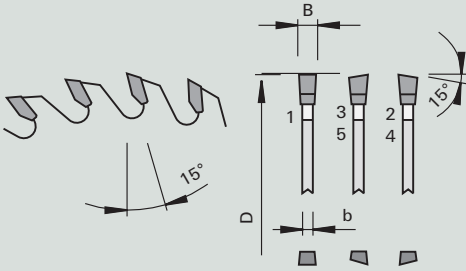
Formaat-cirkelzaagbladen HW - vlakland-wisseltand-wisseltand

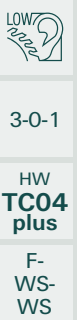
<p>Product</p> 	<p>Tekening</p> 	<p>Machine</p> 	<p>Toepassing</p> 	<p>Uitvoering</p> 
--	--	--	---	---

<p>Machine / gebruiksaanwijzing</p> <ul style="list-style-type: none"> • Tafelcirkelzagen • Kap- en radiaalcirkelzagen • Voor een zuivere snede in plaatmaterialen, massief hout en kunststoffen 	<p>Uitvoering</p> <ul style="list-style-type: none"> • Tandvorm: vlakland-wisseltand-wisseltand "F-WS-WS" • Tandbezetting: HW TC04 plus 	<p>Voordelen</p> <ul style="list-style-type: none"> • Optimale snijkwaliteit voor dwarssneden (afkorten) • Optimale zuivere snede door speciale tandgeometrie • Extreem lange standtijd • Geluidsreductie door laserornamenten 	<p>Informatie - Tip</p> <ul style="list-style-type: none"> • Nmax absoluut niet overschrijden !!
---	---	--	---



Producteigenschappen							Bestelinformatie					
Ø D [mm]	B [mm]	b [mm]	Ø d [mm]	Z	Snikkwaliteit*	NL**		Spaanhoek [°]		VE [St.]	V	ID - No
180	3,0	2,2	30	60	▲▲▲▲	4/6/52		15		1	L	58808701
200	3,0	2,2	30	65	▲▲▲▲			15		1	L	58808702
216	3,0	2,2	30	60	▲▲▲▲	Combi3	Bosch 635-216	15		1	L	58808714
220	3,0	2,2	30	70	▲▲▲▲	8/6/52		15		1	L	58808712
220	3,0	2,2	40	70	▲▲▲▲	8/6/52		15		1	L	58808703
240	3,0	2,2	30	75	▲▲▲▲			15		1	L	192791
250	3,0	2,2	30	80	▲▲▲▲	Combi3		15		1	L	58808706
280	3,0	2,2	30	85	▲▲▲▲	Combi3		15		1	L	58808705
300	3,0	2,2	30	100	▲▲▲▲	Combi3		15		1	L	58808708
300	4,0	3,2	30	100	▲▲▲▲	Combi3	Fimal	15		1	L	58808713
303	3,2	2,2	30	100	▲▲▲▲	Combi3		15		1	L	58808707
350	3,0	2,2	30	100	▲▲▲▲	Combi3		15		1	L	58808709
500	3,6	2,8	30	145	▲▲▲▲	Combi3		15		1	L	58808710
550	4,0	3,2	30	160	▲▲▲▲	Combi3		15		1	L	58808711

* Snijkwaliteit ▲ Zeer grove snede, ▲▲ Grove snede, ▲▲▲ Fijne snede, ▲▲▲▲ Zeer fijne snede
 ** Extra gaten: Combi1 komt overeen met 2/10/60 + 2/7/42 Combi2 komt overeen met 2/7/42 + 2/9/46 en 2/10/60 Combi3 = 2/10/60 + 2/9/46 + 2/9,5/46,5 + 2/7/42 Combi5 = 2/7/110 + 2/9/110 + 2/8,4/130 + 2/14/110 + 4/9/100 + 4/19/120 Combi7 = 2/9/110 + 2/10/80 + 2/11/85 + 2/11/115 + 2/11/148 + 2/14/100 + 2/14/125 + 2/19/120
 Geschikte reduceerringen vindt u aan het einde van deze catalogus

HW

TRF

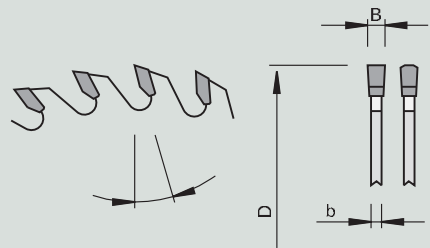
Formaat cirkelzaagbladen HW - trapezium-vlaktand

Product	Tekening	Machine	Toepassing	Uitvoering
				2-0-6 HW TC06 TR-F

Machine / gebruiksaanwijzing	Uitvoering	Voordelen	Informatie - Tip
<ul style="list-style-type: none"> • Handcirkelzagen • Tafelcirkelzagen • Verticale platenopdeelzagen • voor formaatsneden in kunststof beplakte plaatmaterialen 	<ul style="list-style-type: none"> • Tandvorm: trapezium-vlaktand 'TR-F' • Snijmateriaal HW TC06 		<ul style="list-style-type: none"> • Asgat vergroten tegen meerprijs mogelijk tot Ø 50 mm



Producteigenschappen							Bestelinformatie				
Ø D [mm]	B [mm]	b [mm]	Ø d [mm]	Z	Snijkwaliteit*	NL**	Spaanhoek [°]	VE [St.]	V	ID - No	
120	1,8	1,2	20	40	▲▲		5	●	1 L	58104063	
160	2,2	1,6	20	48	▲▲	2/7/32	5	●	1 L	58110161	
160	2,2	1,6	20	56	▲▲▲	2/7/32	5	●	1 L	58110142	
190	2,6	2,0	20FX	54	▲▲▲	Fast-Fix	5	●	1 L	58110229	
190	2,2	1,6	30	56	▲▲▲		5	●	1 L	58458779	
216	3,2	2,2	30	60	▲▲▲		5	●	1 L	58458780	
220	3,2	2,2	30	64	▲▲▲	2/7/42	5	●	1 L	58100399	
232	3,2	2,2	30	64	▲▲▲		5	●	1 #	58458781	
250	3,2	2,2	30	60	▲▲	Combi3	5	●	1 L	58100385	
250	3,2	2,2	30	80	▲▲▲	Combi3	5	●	1 L	58100386	
254	2,4	1,8	30	80	▲▲▲	Combi3	Festool 5	●	1 L	58100402	
300	3,2	2,2	30	72	▲▲	Combi3	5	●	1 L	58100387	
300	3,2	2,2	30	96	▲▲▲	Combi3	5	●	1 L	58100388	
350	3,5	2,5	30	72	▲▲	Combi3	10	●	1 L	58100300	
350	3,5	2,5	30	108	▲▲▲	Combi3	10	●	1 L	58100389	

* Snijkwaliteit ▲ Zeer grove snede, ▲▲ Grove snede, ▲▲▲ Fijne snede, ▲▲▲▲ Zeer fijne snede

** Extra gaten: Combi1 komt overeen met 2/10/60 + 2/7/42 Combi2 komt overeen met 2/7/42 + 2/9/46 en 2/10/60 Combi3 = 2/10/60 + 2/9/46 + 2/9,5/46,5 + 2/7/42 Combi5 = 2/7/110 + 2/9/110 + 2/8,4/130 + 2/14/110 + 4/9/100 + 4/19/120 Combi7 = 2/9/110 + 2/10/80 + 2/11/85 + 2/11/115 + 2/11/148 + 2/14/100 + 2/14/125 + 2/19/120

Geschikte reduceerringen vindt u aan het einde van deze catalogus

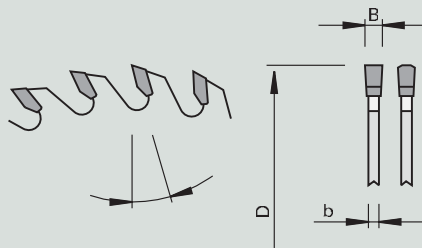
HW TRF - 1
Formaat cirkelzaagbladen HW - trapezium-vlaktand

<p>Product</p> 	<p>Tekening</p> 	<p>Machine</p> 	<p>Toepassing</p> 	<p>Uitvoering</p> <p>3-0-1</p> <p>HW TC04 plus</p> <p>TR- F</p>
--	--	--	---	---

<p>Machine / gebruiksaanwijzing</p> <ul style="list-style-type: none"> • Tafelcirkelzagen • Verticale platenopdeelzagen • voor formaatsneden in kunststof beplakte plaatmaterialen 	<p>Uitvoering</p> <ul style="list-style-type: none"> • Tandvorm: trapezium-vlaktand "TR-F" • Snijmateriaal HW TC04 plus 	<p>Voordelen</p> <ul style="list-style-type: none"> • Verbeterde snijkwaliteit door geoptimaliseerde snijgeometrie • Geluidsreductie door laserornamenten 	<p>Informatie - Tip</p> <ul style="list-style-type: none"> • Speciaal geschikt voor met kunststof bekleed plaatmateriaal op basis van hout en multiplex-platen
---	---	---	---

Producteigenschappen							Bestelinformatie			
Ø D [mm]	B [mm]	b [mm]	Ø d [mm]	Z	Snijkwaliteit*	NL**	Spaanhoek [°]	VE [St.]	V	ID - No
300	3,2	2,2	30	96	▲▲▲	Combi3	5	1	L	58458788
315	3,2	2,2	30	96	▲▲▲	Combi3	5	1	L	58803823
350	3,5	2,5	30	72	▲▲	Combi3	10	1	L	58807830
350	3,5	2,5	30	108	▲▲▲	Combi3	10	1	L	58807831



* Snijkwaliteit ▲ Zeer grove snede, ▲▲ Grove snede, ▲▲▲ Fijne snede, ▲▲▲▲ Zeer fijne snede

** Extra gaten: Combi1 komt overeen met 2/10/60 + 2/7/42 Combi2 komt overeen met 2/7/42 + 2/9/46 en 2/10/60 Combi3 = 2/10/60 + 2/9/46 + 2/9,5/46,5 + 2/7/42 Combi5 = 2/7/110 + 2/9/110 + 2/8,4/130 + 2/14/110 + 4/9/100 + 4/19/120 Combi7 = 2/9/110 + 2/10/80 + 2/11/85 + 2/11/115 + 2/11/148 + 2/14/100 + 2/14/125 + 2/19/120

Geschikte reduceerringen vindt u aan het einde van deze catalogus

HW Cirkelzaagbladen-set HW - een klus voor twee

Set = HW Hoofdcirkelzaagblad en Ritszaag

Product	Tekening	Machine	Toepassing	Uitvoering
				2-0-6 HW TC06 TR-F

Machine / gebruiksaanwijzing	Uitvoering	Voordelen	Informatie - Tip
<ul style="list-style-type: none"> Tafelcirkelzagen met voorrits-aggregaat Platenopdeelzagen met voorrits-aggregaat Voor afwerksnedes in met kunststof bekleed plaatmateriaal op basis van hout 	<ul style="list-style-type: none"> Cirkelzaagbladen-set bestaande uit hoofd- en voorritszaagblad en reduceerring Tandbezetting: HW TC06 	<ul style="list-style-type: none"> Set exact op elkaar afgestemd, dit garandeert een uitstekende snijkwaliteit bij afwerksnedes Snelle, eenvoudige instelling van rits- en hoofdzaag Lange standtijd door speciaal hardmetaal Geluidsreductie door laserornamenten 	

Producteigenschappen		Bestelinformatie			
			VE [St.]	V	ID - No
Cirkelzaagbladen-set HW - een klus voor twee			1	L	50804303
Toebehoren	Afmeting [mm]		VE [St.]	V	ID - No
Hoofdcirkelzaagblad	300x3,2x2,2x30 Z=72 TR-F		1	L	58100387
Ritscirkelzaagblad	125x3,35x2,4x22 Z=24 WS		1	L	50806200
Reduceerringen	22x2,0x20		1	L	161887

Producteigenschappen		Bestelinformatie			
			VE [St.]	V	ID - No
Cirkelzaagbladen-set HW - een klus voor twee			1	L	58804305
Toebehoren	Afmeting [mm]		VE [St.]	V	ID - No
Hoofdcirkelzaagblad	300x3,2x2,2x30 Z=72 TR-F		1	L	58100387
Ritscirkelzaagblad	120x3,35x2,4x22 Z=24 WS		1	S	58806209
Reduceerringen	22x2,0x20		1	L	161887

Producteigenschappen		Bestelinformatie			
			VE [St.]	V	ID - No
Cirkelzaagbladen-set HW - een klus voor twee		Altendorf	1	L	58804304
Toebehoren	Afmeting [mm]		VE [St.]	V	ID - No
Hoofdcirkelzaagblad	350x3,5x2,4x30 Z=72 TR-F		1	L	58807830
Ritscirkelzaagblad	180x3,6x2,4x22 Z=36 F		1	L	58806210

* **Snijkwaliteit** ▲ Zeer grove snede, ▲▲ Grove snede, ▲▲▲ Fijne snede, ▲▲▲▲ Zeer fijne snede

** **Extra gaten:** **Combi1** komt overeen met 2/10/60 + 2/7/42 **Combi2** komt overeen met 2/7/42 + 2/9/46 en 2/10/60 **Combi3** = 2/10/60 + 2/9/46 + 2/9,5/46,5 + 2/7/42 **Combi5** = 2/7/110 + 2/9/110 + 2/8,4/130 + 2/14/110 + 4/9/100 + 4/19/120 **Combi7** = 2/9/110 + 2/10/80 + 2/11/85 + 2/11/115 + 2/11/148 + 2/14/100 + 2/14/125 + 2/19/120

Geschikte **reduceerringen** vindt u aan het einde van deze catalogus

HW RSK - nn-System
Voorrits cirkelzaagbladen HW - conische-vlaktand - nn-systeem

Product

Tekening

Machine

Toepassing

Uitvoering

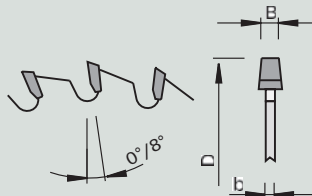

3-0-1

HW
TC04 plus

KO-F

Machine / gebruiksaanwijzing

- Tafelcirkelzagen
- Voor het voorritsen van met kunststof beplakte plaatmaterialen

Uitvoering

- Speciale NoNoise-spaanruimtegeometrie
- Tandvorm: conische-vlaktand 'KO-F'
- Snijmateriaal HW TCO4 plus

Voordelen

- Snel verstelbaar
- Universeel inzetbaar
- Verbeterde snijkwaliteit door hogere looppauwkeurigheid (industrie uitvoering)
- Vermindering van de ritsdiepte
- Extreem geluidsarm
- Geluidsreducering met ca. 6 dB(A) bij stationair draaien
- Zeer goede snijkwaliteit bij alle standaardcoatings
- Lange standtijden zorgen voor de nodige productiviteit en rendabiliteit

Informatie - Tip

- Door hoogteverstelling van de as op snijbreedte van de hoofdzaag in te stellen
- 1 mm ritsdiepte = 0,21 mm snijbreedte
- Optimale voorrits-diepte 1,0 - 2,0 mm

Producteigenschappen

Bestelinformatie

Ø D [mm]	B [mm]	b [mm]	Ø d [mm]	Z	Snijkwaliteit*	Spaanhoek [°]			VE [St.]	V	ID - No
100	3,2-4,0	2,5	20	20	▲▲▲▲	8	Schelling	🌿	1	L	58807950
120	3,2-4,0	2,5	20	24	▲▲▲▲	8	Altendorf, SCM	🌿	1	L	58807951
120	3,2-4,0	2,5	22	24	▲▲▲▲	8	Altendorf, Martin	🌿	1	L	58807952
125	3,1-4,0	2,5	20	24	▲▲▲▲	8	Panhans, Paolini	🌿	1	L	58807953

* Snijkwaliteit ▲ Zeer grove snede, ▲▲ Grove snede, ▲▲▲ Fijne snede, ▲▲▲▲ Zeer fijne snede

** Extra gaten: Combi1 komt overeen met 2/10/60 + 2/7/42 Combi2 komt overeen met 2/7/42 + 2/9/46 en 2/10/60 Combi3 = 2/10/60 + 2/9/46 + 2/9,5/46,5 + 2/7/42 Combi5 = 2/7/110 + 2/9/110 + 2/8,4/130 + 2/14/110 + 4/9/100 + 4/19/120 Combi7 = 2/9/110 + 2/10/80 + 2/11/85 + 2/11/115 + 2/11/148 + 2/14/100 + 2/14/125 + 2/19/120

Geschikte reduceerringen vindt u aan het einde van deze catalogus

DP RSK Voorrits cirkelzaagblad DP - conische-vlaktand KO-F

Product



Tekening

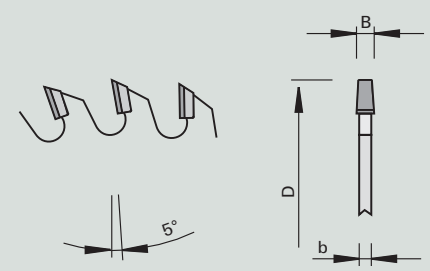

Machine



Toepassing



Uitvoering



4,5 mm

3-0-1

KO-F

<p>Machine / gebruiksaanwijzing</p> <ul style="list-style-type: none"> Tafelcirkelzagen Voor het voorritsen van beplakte plaatmaterialen 	<p>Uitvoering</p> <ul style="list-style-type: none"> Diamantsnijkmanten in gepolijste uitvoering Tandvorm: conische vlaktand "KO-F" Snijmateriaal DP Naslijpzone 4,5 mm 	<p>Voordelen</p> <ul style="list-style-type: none"> Korte levertijden 	<p>Informatie - Tip</p> <ul style="list-style-type: none"> Inzetten in meeloop Door hoogtereverstelling van de as op snijbreedte van de hoofdzaag in te stellen
--	---	--	---

Producteigenschappen							Bestelinformatie				
Ø D [mm]	B [mm]	b [mm]	Ø d [mm]	Z	Snijkwaliteit*	Spaanhoek [°]		VE [St.]	V	ID - No	
120	3,1-3,9	2,5	22	16	▲▲▲▲	5	Altendorf, Martin	1	S	58750101	

DP RSVS Voorrits cirkelzaagbladen DP - verstelbaar wisseltand WS

Product



Tekening

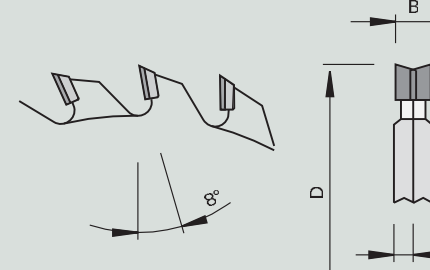

Machine



Toepassing



Uitvoering



4,5 mm

3-0-1

WS

<p>Machine / gebruiksaanwijzing</p> <ul style="list-style-type: none"> Tafelcirkelzagen Voor het voorritsen van diverse beplakte plaatmaterialen 	<p>Uitvoering</p> <ul style="list-style-type: none"> Tandvorm: wisseltand "WS" Snijmateriaal DP Naslijpzone 4,5 mm 	<p>Voordelen</p>	<p>Informatie - Tip</p> <ul style="list-style-type: none"> Tweedelig, snijbreedte dmv tussenringen instelbaar Inzet in meeloop
--	---	------------------	--

Producteigenschappen							Bestelinformatie				
Ø D [mm]	B [mm]	b [mm]	Ø d [mm]	Z	Snijkwaliteit*	NL**	Spaanhoek [°]		VE [St.]	V	ID - No
120	2,8-3,8	2,2	22	2x12	▲▲▲▲	2/3,8/42	8	Altendorf, Martin	1	S	50750102
120	2,8-3,8	2,2	50	2x12	▲▲▲▲	4/6,2/62	8	Altendorf versteelenheid	1	S	189104

* Snijkwaliteit ▲ Zeer grove snede, ▲▲ Grove snede, ▲▲▲ Fijne snede, ▲▲▲▲ Zeer fijne snede
 ** Extra gaten: Combi1 komt overeen met 2/10/60 + 2/7/42 Combi2 komt overeen met 2/7/42 + 2/9/46 en 2/10/60 Combi3 = 2/10/60 + 2/9/46 + 2/9,5/46,5 + 2/7/42 Combi5 = 2/7/110 + 2/9/110 + 2/8,4/130 + 2/14/110 + 4/9/100 + 4/19/120 Combi7 = 2/9/110 + 2/10/80 + 2/11/85 + 2/11/115 + 2/11/148 + 2/14/100 + 2/14/125 + 2/19/120
 Geschikte reduceerringen vindt u aan het einde van deze catalogus

HW

RS2

Voorrits cirkelzaagbladen HW - verstelbaar vlakland F

Product

Tekening

Machine

Toepassing

Uitvoering

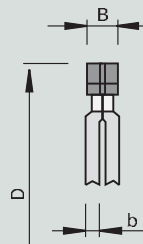
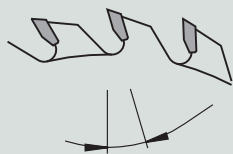

3-0-1

HW
TC03

F

Machine / gebruiksaanwijzing

- Tafelcirkelzagen
- Platenopdeelzagen
- Platenopdeelzagen met instelbare voorritsaggregaat
- Voor het voorritsen van met kunststof beplakte plaatmaterialen

Uitvoering

- Tandvorm: vlakland "F"
- Tandbezetting: HW TC03

Voordelen

- Universeel inzetbaar

Informatie - Tip

- Tweedelig, snijbreedte dmv tussenringen instelbaar

Producteigenschappen

Bestelinformatie

Ø D [mm]	B [mm]	b [mm]	Ø d [mm]	Z	Snijkwaliteit*	Spaanhoek [°]			VE [St.]	V	ID - No
80	2,8-3,6	2,2	20	2x10	▲▲▲▲	12			1	L	58802435
100	2,8-3,6	2,2	20	2x10	▲▲▲▲	12			1	L	58110190
100	2,8-3,6	2,2	22	2x10	▲▲▲▲	12			1	L	58110188
105	2,8-3,6	2,2	20	2x10	▲▲▲▲	12			1	L	58110171
120	2,8-3,6	2,2	20	2x12	▲▲▲▲	12			1	L	58110186
120	2,8-3,6	2,2	22	2x12	▲▲▲▲	12			1	L	58110187
125	2,8-3,6	2,2	20	2x12	▲▲▲▲	12			1	L	58110206
125	2,8-3,6	2,2	22	2x12	▲▲▲▲	12			1	L	58110204

* Snijkwaliteit ▲ Zeer grove snede, ▲▲ Grove snede, ▲▲▲ Fijne snede, ▲▲▲▲ Zeer fijne snede



** Extra gaten: Combi1 komt overeen met 2/10/60 + 2/7/42 Combi2 komt overeen met 2/7/42 + 2/9/46 en 2/10/60 Combi3 = 2/10/60 + 2/9/46 + 2/9,5/46,5 + 2/7/42 Combi5 = 2/7/110 + 2/9/110 + 2/8,4/130 + 2/14/110 + 4/9/100 + 4/19/120 Combi7 = 2/9/110 + 2/10/80 + 2/11/85 + 2/11/115 + 2/11/148 + 2/14/100 + 2/14/125 + 2/19/120

Geschikte reduceerringen vindt u aan het einde van deze catalogus

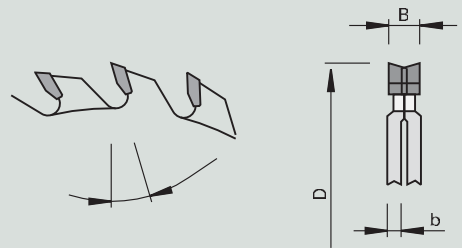

HW

RSVS

Voorrits cirkelzaagbladen HW - verstelbaar wisseltand WS

Product	Tekening	Machine	Toepassing	Uitvoering
				3-0-1 HW TC03 WS

Machine / gebruiksaanwijzing	Uitvoering	Voordelen	Informatie - Tip
<ul style="list-style-type: none"> Tafelcirkelzagen Platenopdeelzagen Platenopdeelzagen met instelbare voorritsaggregaat Voor het voorritsen van met kunststof beplakte plaatmaterialen 	<ul style="list-style-type: none"> Tandvorm: wisseltand 'WS' Snijmateriaal HW TC03 	<ul style="list-style-type: none"> Kleinere motorbelasting door WS-tandvorm 	<ul style="list-style-type: none"> Tweedelig, snijbreedte dmv tussenringen instelbaar

Producteigenschappen							Bestelinformatie					
Ø D [mm]	B [mm]	b [mm]	Ø d [mm]	Z	Snijkwaliteit*	Spaanhoek [°]				VE [St.]	V	ID - No
120	2,8-3,8	2.2	22	2x12	▲▲▲▲	12		Martin NC versteenheid		1	L	50807854
120	2,8-3,8	2.2	50	2x12	▲▲▲▲	12		Altendorf, Martin		1	L	50807902
140	2,8-3,6	2.0	36	2x12	▲▲▲▲	12		Martin T75 PreX		1	L	193258
Toebehoren		Afmeting [mm]								VE [St.]	V	ID - No
Kruiskopschroeven - met binnentorx		M5x6,8 T15 D=Ø9,4		Montageschroef voor binnenflens						10	L	180839
Kruiskopschroeven - met binnentorx		M5x10,8 T15 D=Ø9,4		Montageschroef voor buitenflens						10	L	827277





* Snijkwaliteit ▲ Zeer grove snede, ▲▲ Grove snede, ▲▲▲ Fijne snede, ▲▲▲▲ Zeer fijne snede

** Extra gaten: Combi1 komt overeen met 2/10/60 + 2/7/42 Combi2 komt overeen met 2/7/42 + 2/9/46 en 2/10/60 Combi3 = 2/10/60 + 2/9/46 + 2/9,5/46,5 + 2/7/42 Combi5 = 2/7/110 + 2/9/110 + 2/8,4/130 + 2/14/110 + 4/9/100 + 4/19/120 Combi7 = 2/9/110 + 2/10/80 + 2/11/85 + 2/11/115 + 2/11/148 + 2/14/100 + 2/14/125 + 2/19/120

Geschikte reduceerringen vindt u aan het einde van deze catalogus

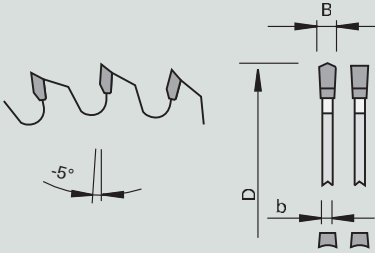
HW KDF - Industry - Negatief

Formaat cirkelzaagbladen HW - daktand-vlaktand Duplovit



Product	Tekening	Machine	Toepassing	Uitvoering
				3-0-1  HW TC06 DA-F DU

Machine / gebruiksaanwijzing	Uitvoering	Voordelen	Informatie - Tip
<ul style="list-style-type: none"> • Kap- en radiaal cirkelzagen • Tafelcirkelzagen • Verticale platenopdeelzagen • Voor dwarssnedes bij profieldelen van kunststof en massief hout 	<ul style="list-style-type: none"> • Trilling- en geluiddempende ornamenten • Extra spannings sleuven • Tandvorm: daktand-vlaktand Duplovit 'DA-F DU' • Snijmateriaal HW TC06 	<ul style="list-style-type: none"> • Extreem geluidsarm door vibratie- en geluiddempende ornamenten en speciale spannings sleuven • Goede afwerking aan onderzijde ook zonder voorrits-zaagblad • Beste snijkwaliteit 	

Producteigenschappen						Bestelinformatie					
Ø D [mm]	B [mm]	b [mm]	Ø d [mm]	Z	Snijkwaliteit*	NL**	Spaanhoek [°]	VE [St.]	V	ID - No	
250	3,2	2,2	30	48	▲▲▲	Combi3	-5		1 L	58804352	
303	3,2	2,2	30	60	▲▲▲▲	Combi3	-5		1 L	58804279	

HW KDF - Industry

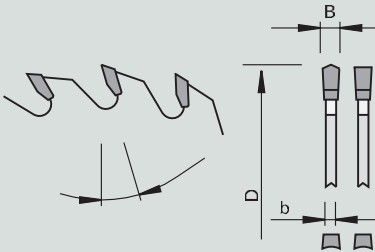
Formaat cirkelzaagbladen HW - daktand-vlaktand Duplovit

Product	Tekening	Machine	Toepassing	Uitvoering
				3-0-1 HW TC06 DA-F DU

Machine / gebruiksaanwijzing	Uitvoering	Voordelen	Informatie - Tip
<ul style="list-style-type: none"> • Tafelcirkelzagen • Vertikale platenopdeelzaagbladen • Voor formaatsnedes in ruw en beplakt plaatmateriaal op basis van hout 	<ul style="list-style-type: none"> • Trilling- en geluiddempende ornamenten • Extra spannings sleuven • Tandvorm: daktand-vlaktand Duplovit 'DA-F DU' • Snijmateriaal HW TC06 	<ul style="list-style-type: none"> • Extreem geluidsarm door vibratie- en geluiddempende ornamenten zoals speciale sleufcombinaties • Goede afwerking aan onderzijde ook zonder voorrits-zaagblad • Beste snijkwaliteit 	

Producteigenschappen						Bestelinformatie					
Ø D [mm]	B [mm]	b [mm]	Ø d [mm]	Z	Snijkwaliteit*	NL**	Spaanhoek [°]	VE [St.]	V	ID - No	
220	3,2	2,2	30	42	▲▲	2/7/42	10		1 L	58804281	
250	3,2	2,2	30	48	▲▲	Combi3	10		1 L	58804351	
303	3,2	2,2	30	60	▲▲▲▲	Combi3	10		1 L	58804353	
350	3,5	2,5	30	72	▲▲▲▲	Combi3	10		1 L	58804280	

* Snijkwaliteit ▲ Zeer grove snede, ▲▲ Grove snede, ▲▲▲ Fijne snede, ▲▲▲▲ Zeer fijne snede

** Extra gaten: Combi1 komt overeen met 2/10/60 + 2/7/42 Combi2 komt overeen met 2/7/42 + 2/9/46 en 2/10/60 Combi3 = 2/10/60 + 2/9/46 + 2/9,5/46,5 + 2/7/42 Combi5 = 2/7/110 + 2/9/110 + 2/8,4/130 + 2/14/110 + 4/9/100 + 4/19/120 Combi7 = 2/9/110 + 2/10/80 + 2/11/85 + 2/11/115 + 2/11/148 + 2/14/100 + 2/14/125 + 2/19/120

Geschikte reduceerringen vindt u aan het einde van deze catalogus

HW KDF - Industry Plus

Formaat cirkelzaagblad HW - daktand-vlaktand met fase Duplovit

Product	Tekening	Machine	Toepassing	Uitvoering
				<p>LONG LIFE</p> <p>LOW NOISE</p> <p>3-0-1</p> <p>DA-F-FA DU</p>

Machine / gebruiksaanwijzing	Uitvoering	Voordelen	Informatie - Tip
<ul style="list-style-type: none"> Tafelcirkelzagen Vertikale platenzagen Voor formaatsnedes in ruw en beplakt plaatmateriaal op basis van hout 	<ul style="list-style-type: none"> Trilling- en geluiddempende ornamenten Extra spanningsseuven Tandvorm: daktand-vlaktand met fase Duplovit 'DA-F-FA DU' Snijmateriaal HW TC06 	<ul style="list-style-type: none"> Extreem geluidsarm door vibratie- en geluiddempende ornamenten en speciale spanningsseuven Nette onderzijde ook zonder voorrits cirkelzaagblad Gereduceerde snijdruk Verlengde standtijd Verbeterde snijkwaliteit 	

Producteigenschappen							Bestelinformatie				
Ø D [mm]	B [mm]	b [mm]	Ø d [mm]	Z	Snijkwaliteit*	NL**	Spaanhoek [°]	VE [St.]	V	ID - No	
303	3,2	2,2	30	60	▲▲▲▲	Combi3	10		1 L	58804301	

HW KDF - Industry Professional

Formaat cirkelzaagblad HW - trapezium-vlaktand-vlaktand Duplovit

Product	Tekening	Machine	Toepassing	Uitvoering
				<p>LOW NOISE</p> <p>3-0-1</p> <p>HW TC03</p> <p>TR-F-F DU</p>

Machine / gebruiksaanwijzing	Uitvoering	Voordelen	Informatie - Tip
<ul style="list-style-type: none"> Tafelcirkelzagen Vertikale platenzagen Voor formaatsnedes in (on)beplakte en kunststof beplakte plaatmaterialen 	<ul style="list-style-type: none"> Trilling- en geluiddempende ornamenten Extra spanningsseuven Tandvorm: trapezium-vlaktand-vlaktand Duplovit 'TR-F-F DU' Snijmateriaal HW TC03 	<ul style="list-style-type: none"> Extreem geluidsarm door vibratie- en geluiddempende ornamenten en speciale spanningsseuven Goede afwerking aan onderzijde ook zonder voorrits-zaagblad Beste snijkwaliteit door innovatieve groepenvertangding 	

Producteigenschappen							Bestelinformatie				
Ø D [mm]	B [mm]	b [mm]	Ø d [mm]	Z	Snijkwaliteit*	NL**	Spaanhoek [°]	VE [St.]	V	ID - No	
303	3,5	2,5	30	60	▲▲▲▲	Combi3	10		1 L	58804282	

* Snijkwaliteit ▲ Zeer grove snede, ▲▲ Grove snede, ▲▲▲ Fijne snede, ▲▲▲▲ Zeer fijne snede

** Extra gaten: Combi1 komt overeen met 2/10/60 + 2/7/42 Combi2 komt overeen met 2/7/42 + 2/9/46 en 2/10/60 Combi3 = 2/10/60 + 2/9/46 + 2/9,5/46,5 + 2/7/42 Combi5 = 2/7/110 + 2/9/110 + 2/8,4/130 + 2/14/110 + 4/9/100 + 4/19/120 Combi7 = 2/9/110 + 2/10/80 + 2/11/85 + 2/11/115 + 2/11/148 + 2/14/100 + 2/14/125 + 2/19/120

Geschiedte reduceerringen vindt u aan het einde van deze catalogus

DP HRP - nn-System DP flex
 Formaat cirkelzaagbladen DP - hollerugtand

Product



Tekening

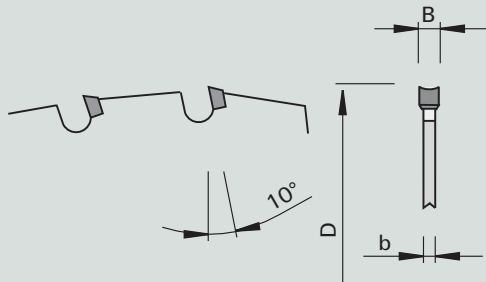

Machine



Toepassing



Uitvoering



NO 2000

3-0-1

HR





- | | | | |
|--|--|---|---|
| <p>Machine / gebruiksaanwijzing</p> <ul style="list-style-type: none"> • Formaat- en tafelcirkelzagen • Verticale platenopdeelzagen • Afkortzagen • Voor precisiesnedes in alle gangbare platen op basis van hout • Voor langs- en dwarsnedes in massief hout | <p>Uitvoering</p> <ul style="list-style-type: none"> • Tandvorm: hollerugtand 'HR' • Snijmateriaal: DP • 2 keer naslijpbaar • Speciale snijgeometrie • Kleine spaanruimtes • Stamblad gecoat | <p>Voordelen</p> <ul style="list-style-type: none"> • Bijzonder prettig werken door nauwelijks waarneembare geluidsontwikkeling • Hoogste rendabiliteit en productiviteit door extreem lange standtijd • Verminderde snijdruk door holleruggeometrie • Coating beschermt tegen corrosie, hechting van vreemde materialen en vermindert de wrijving bij het stamblad | <p>Informatie - Tip</p> <ul style="list-style-type: none"> • Niet aanbevolen voor lengtesnedes in zacht hout en materiaaldikte van meer dan 40 mm • Braamvrije snedes kunnen alleen in combinatie met een geschikt voorrits cirkelzaagblad worden gegarandeerd • LET OP! Het spouwmes moet voor deze cirkelzaagbladen tussen de 2,0 en 2,4 mm dik zijn. • Leveringsomvang: spouwmes apart bestellen |
|--|--|---|---|

Producteigenschappen							Bestelinformatie				
Ø D [mm]	B [mm]	b [mm]	Ø d [mm]	Z	Snijkwaliteit*	NL**	Spaanhoek [°]	VE [St.]	V	ID - No	
250	2,5	2,0	30	50	▲▲▲	Combi2 + 8/5,2/90	10	1	L	58459455	
303	2,5	2,0	30	60	▲▲▲	Combi2 + 8/5,2/90	10	1	L	58459439	
350	2,5	2,0	30	72	▲▲▲	Combi2 + 8/5,2/90	10	1	L	58459446	
Toebehoren		Ø D [mm]	B [mm]								
Spouwmes		300-350	2,25	Altendorf F45							
Spouwmes		240-250	2,25	HOLZ-HER Vertikal							
Spouwmes		300-350	2,25	Striebig Standard III Control Evolution							
Spouwmes		300-350	2,25	Striebig Standard Eco							
Spouwmes		300	2,25	Putsch							
Spouwmes		250-350	2,25	Martin T60A							
Spouwmes		303	2,2	Elcon							
Spouwmes		300-350	2,2	SCM Standard							
Spouwmes		290-303	2,2	Striebig Typ 5220A							
Spouwmes		250-315	2,2	Fleder							
Spouwmes		250-315	2,2	Felder Format4							
Spouwmes		300-350	2,23	Griggio E3200							
Spouwmes		350	2,2	SCM SI3200							
Spouwmes		303	2,2	Holz-Her Supercut							
Spouwmes		250-315	2,2	SCM SC3W							

* **Snijkwaliteit** ▲ Zeer grove snede, ▲▲ Grove snede, ▲▲▲ Fijne snede, ▲▲▲▲ Zeer fijne snede
 ** **Extra gaten:** Combi1 komt overeen met 2/10/60 + 2/7/42 Combi2 komt overeen met 2/7/42 + 2/9/46 en 2/10/60 Combi3 = 2/10/60 + 2/9/46 + 2/9,5/46,5 + 2/7/42 Combi5 = 2/7/110 + 2/9/110 + 2/8,4/130 + 2/14/110 + 4/9/100 + 4/19/120 Combi7 = 2/9/110 + 2/10/80 + 2/11/85 + 2/11/115 + 2/11/148 + 2/14/100 + 2/14/125 + 2/19/120
 Geschikte **reduceerringen** vindt u aan het einde van deze catalogus

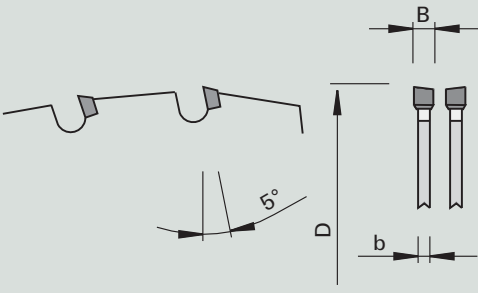
DP **RSK - nn-System DP flex**
Voorrits cirkelzaagbladen DP - wisseltand



<p>Product</p> 	<p>Tekening</p> 	<p>Machine</p> 	<p>Toepassing</p> 	<p>Uitvoering</p> 
--	--	--	---	---

<p>Machine / gebruiksaanwijzing</p> <ul style="list-style-type: none"> • Formaat- en tafelcirkelzagen • Voor precisiesnedes in alle gangbare platen op basis van hout • Voor langs- en dwarsnedes in massief hout 	<p>Uitvoering</p> <ul style="list-style-type: none"> • Tandvorm: wisseltand 'WS' • Snijmateriaal: DP • 2 keer naslijpbaar • Speciale snijgeometrie • Kleine spaanruimtes • Stamblad gecoat 	<p>Voordelen</p> <ul style="list-style-type: none"> • Bijzonder prettig werken door nauwelijks waarneembare geluidsontwikkeling • Hoogste rendabiliteit en productiviteit door extreem lange standtijd • Coating beschermt tegen corrosie, hechting van vreemde materialen en vermindert de wrijving bij het stamblad 	<p>Informatie - Tip</p>
--	--	--	-------------------------

Producteigenschappen							Bestelinformatie				
Ø D [mm]	B [mm]	b [mm]	Ø d [mm]	Z	Snijkwaliteit*	Spaanhoek [°]		VE [St.]	V	ID - No	
120	2,6	2,0	20	24	▲▲▲▲	8		1	L	192448	
120	2,6	2,0	22	24	▲▲▲▲	8		1	L	192447	
125	2,6	2,0	20	24	▲▲▲▲	8		1	L	192449	
180	2,6	2,0	22	36	▲▲▲▲	8		1	S	192964	



* Snijkwaliteit ▲ Zeer grove snede, ▲▲ Grove snede, ▲▲▲ Fijne snede, ▲▲▲▲ Zeer fijne snede

** Extra gaten: Combi1 komt overeen met 2/10/60 + 2/7/42 Combi2 komt overeen met 2/7/42 + 2/9/46 en 2/10/60 Combi3 = 2/10/60 + 2/9/46 + 2/9,5/46,5 + 2/7/42 Combi5 = 2/7/110 + 2/9/110 + 2/8,4/130 + 2/14/110 + 4/9/100 + 4/19/120 Combi7 = 2/9/110 + 2/10/80 + 2/11/85 + 2/11/115 + 2/11/148 + 2/14/100 + 2/14/125 + 2/19/120

Geschikte reduceerringen vindt u aan het einde van deze catalogus

DP RSK - nn-systeem DP flex - verstelbaar
 Voorrits cirkelzaagblad DP 'WS' - verstelbaar

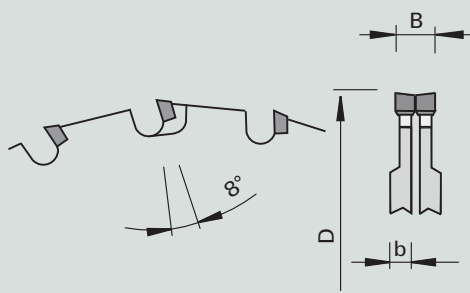

<p>Product</p> 	<p>Tekening</p> 	<p>Machine</p> 	<p>Toepassing</p> 	<p>Uitvoering</p> 
--	--	--	---	---

<p>Machine / gebruiksaanwijzing</p> <ul style="list-style-type: none"> • Formaat- en tafelcirkelzagen • Voor het braamvrij voorritsen van diverse gecoate plaatmaterialen op basis van hout 	<p>Uitvoering</p> <ul style="list-style-type: none"> • Tandvorm: wisseltand 'WS' • Snijmateriaal: DP • 2 keer naslijpbaar • Kleine spaanruimtes • Stamblad gecoat 	<p>Voordelen</p> <ul style="list-style-type: none"> • Nauwelijks waarneembare geluidsontwikkeling • Hoogste rendabiliteit en productiviteit door extreem lange standtijden • Coating beschermt tegen corrosie, hechting van vreemde materialen en vermindert de wrijving bij het stamblad 	<p>Informatie - Tip</p> <ul style="list-style-type: none"> • Altendorf RAPIDO / verstelbaar
---	--	--	--



Producteigenschappen							Bestelinformatie				
Ø D [mm]	B [mm]	b [mm]	Ø d [mm]	Z	Snijkwaliteit*	Spaanhoek [°]		VE [St.]	V	ID - No	
120	2,4-3,2	2,2	50	12+12	▲▲▲▲	8		1	L	192452	

* Snijkwaliteit ▲ Zeer grove snede, ▲▲ Grove snede, ▲▲▲ Fijne snede, ▲▲▲▲ Zeer fijne snede
 ** Extra gaten: Combi1 komt overeen met 2/10/60 + 2/7/42 Combi2 komt overeen met 2/7/42 + 2/9/46 en 2/10/60 Combi3 = 2/10/60 + 2/9/46 + 2/9,5/46,5 + 2/7/42 Combi5 = 2/7/110 + 2/9/110 + 2/8,4/130 + 2/14/110 + 4/9/100 + 4/19/120 Combi7 = 2/9/110 + 2/10/80 + 2/11/85 + 2/11/115 + 2/11/148 + 2/14/100 + 2/14/125 + 2/19/120
 Geschikte reduceerringen vindt u aan het einde van deze catalogus

HW

TFP

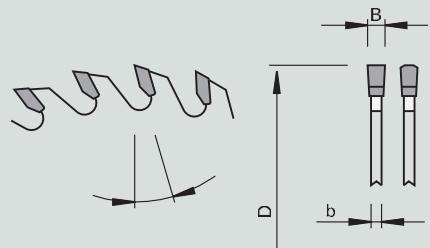
Platenopdeel-cirkelzaagbladen HW - trapezium-vlaktand

Product	Tekening	Machine	Toepassing	Uitvoering
				3-0-1 HW TC04 plus TR-F

Machine / gebruiksaanwijzing	Uitvoering	Voordelen	Informatie - Tip
<ul style="list-style-type: none"> Platenopdeelzagen Voor formaatsneden in kunststof beplakte plaatmaterialen. Eventueel ook te zagen in pakketten 	<ul style="list-style-type: none"> Tandvorm: trapezium-vlaktand "TR-F" Tandbezetting: HW TC04 plus 	<ul style="list-style-type: none"> Verbeterde snijkwaliteit door geoptimaliseerde tandgeometrie Geluidsreductie door laserornamenten 	<ul style="list-style-type: none"> Bijzonder geschikt voor (kunststof) beplakte plaatmaterialen en multiplexen enkelvoudig of gestapeld

Producteigenschappen								Bestelinformatie				
Ø D [mm]	B [mm]	b [mm]	Ø d [mm]	Z	Snijkwaliteit*	NL**	Spaanhoek [°]		VE [St.]	V	ID - No	
300	4,4	3,0	30	60	▲▲▲	Combi3	10	Panhans	1	L	58806053	
320	4,4	3,2	65	72	▲▲▲	3/13/95 + 2/14/110	15	Holzma	1	L	58807818	
350	4,4	3,0	30	72	▲▲▲	Combi3 + 2/13/94	10	SCM, Panhans, Mayer, Schelling, HOLZ-HER	1	L	58807803	
350	4,4	3,2	60	72	▲▲▲	Combi7	10	Holzma 72 HPP 350	1	L	58807955	
355	4,4	3,0	75	72	▲▲▲	4/15/105	10	Gibbe	1	L	58807888	
380	4,4	3,2	60	72	▲▲▲	Combi7	15	Holzma	1	L	58807819	
380	4,8	3,5	60	72	▲▲▲	Combi7	15	Holzma	1	L	58806065	
400	4,4	3,2	30	72	▲▲▲	Combi3 + 2/13/94	15	Schelling, Mayer, Irion, Scheer, HOLZ-HER	1	L	58806069	
400	4,4	3,2	75	72	▲▲▲	4/15/105 + 2/7/110	15	Giben, Homag	1	L	58806071	
400	4,4	3,2	80	72	▲▲▲	Combi5	15	Selco, Irion	1	L	58807809	
420	4,8	3,5	60	72	▲▲▲	Combi7	15	Holzma	1	L	58807956	
430	4,4	3,2	80	72	▲▲▲	Combi5	15	Selco	1	L	58806479	
450	4,4	3,2	30	72	▲▲	Combi3 + 2/13/94	15	Irion, Schelling	1	L	58458789	
450	4,8	3,5	60	72	▲▲▲	Combi7	15	Holzma	1	L	58807817	

* Snijkwaliteit ▲ Zeer grove snede, ▲▲ Grove snede, ▲▲▲ Fijne snede, ▲▲▲▲ Zeer fijne snede

** Extra gaten: Combi1 komt overeen met 2/10/60 + 2/7/42 Combi2 komt overeen met 2/7/42 + 2/9/46 en 2/10/60 Combi3 = 2/10/60 + 2/9/46 + 2/9,5/46,5 + 2/7/42 Combi5 = 2/7/110 + 2/9/110 + 2/8,4/130 + 2/14/110 + 4/9/100 + 4/19/120 Combi7 = 2/9/110 + 2/10/80 + 2/11/85 + 2/11/115 + 2/11/148 + 2/14/100 + 2/14/125 + 2/19/120

Geschikte reduceerringen vindt u aan het einde van deze catalogus

DP TFP Platenopdeelzaagbladen DP - trapezium-vlaktand met tweezijdige fase 

Product



Tekening

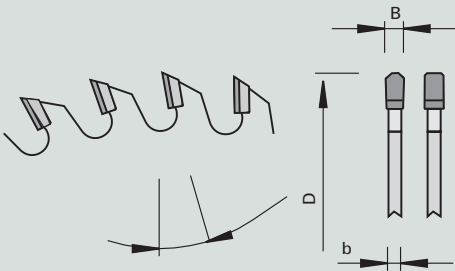

Machine 

Toepassing 

Uitvoering 
4,5 mm

3-0-1

TR-F-FA





- | | | | |
|---|--|---|-------------------------|
| <p>Machine / gebruiksaanwijzing</p> <ul style="list-style-type: none"> • Platenopdeelzagen • Voor formaatsneden in kunststof beplakte plaatmaterialen. Eventueel ook te zagen in pakketten • Focus op universele inzetbaarheid | <p>Uitvoering</p> <ul style="list-style-type: none"> • Trilling- en geluiddempende ornamenten • Diamantsnijkmanten in gepolijste uitvoering • Geoptimaliseerde snijgeometrie per tandvorm voor hoofdzagen en voorritszagen • Tandvorm: trapezium-vlaktand met tweezijdige fase "TR-F-FA" • Snijmateriaal DP • Naslijpzone 4,5 mm | <p>Voordelen</p> <ul style="list-style-type: none"> • Lange levensduur | <p>Informatie - Tip</p> |
|---|--|---|-------------------------|

Producteigenschappen								Bestelinformatie				
Ø D [mm]	B [mm]	b [mm]	Ø d [mm]	Z	Snijkwaliteit*	NL**	Spaanhoek [°]		VE [St.]	V	ID - No	
320	4,4	3,2	65	60	▲▲▲	2/9/110	10			1	S	50750120
350	4,4	3,2	30	72	▲▲▲	Combi3	10	SCM, Panhans, Mayer, Schelling, Scheer		1	S	50750128
350	4,4	3,0	60	72	▲▲▲	Combi7	10	SCM, Panhans, Mayer, Schelling, Scheer		1	S	50750129
380	4,4	3,2	60	72	▲▲▲	2/14/100 + 2/14/125	10	Holzma		1	S	50750130
380	4,8	3,5	60	72	▲▲▲	2/14/100 + 2/14/125	10	Holzma		1	S	50750131
400	4,4	3,2	30	72	▲▲▲	Combi3 + 3/13/94	15	Schelling, Mayer, Scheer, Irion		1	S	50750132
400	4,4	3,2	75	72	▲▲▲	4/15/105 + 2/7/110	15	Giben, Homag		1	S	50750133
400	4,4	3,2	80	72	▲▲▲	Combi5	15	Schelling, Mayer, Scheer, Irion		1	S	50750134
420	4,8	3,5	60	60	▲▲	2/10/80 + 2/14/125	15	Holzma		1	S	50750135
450	4,4	3,2	30	72	▲▲▲		15	Selco		1	S	50750138
450	4,8	3,5	60	72	▲▲▲	Combi7	15	Holzma		1	S	50750136
450	4,8	3,5	80	72	▲▲▲	4/19/120 + 2/8,4/130	15	Selco		1	S	50750137
460	4,4	3,2	30	72	▲▲▲	3/13/94	15	Schelling		1	S	50750146

* **Snijkwaliteit** ▲ Zeer grove snede, ▲▲ Grove snede, ▲▲▲ Fijne snede, ▲▲▲▲ Zeer fijne snede
 ** **Extra gaten:** Combi1 komt overeen met 2/10/60 + 2/7/42 Combi2 komt overeen met 2/7/42 + 2/9/46 en 2/10/60 Combi3 = 2/10/60 + 2/9/46 + 2/9,5/46,5 + 2/7/42 Combi5 = 2/7/110 + 2/9/110 + 2/8,4/130 + 2/14/110 + 4/9/100 + 4/19/120 Combi7 = 2/9/110 + 2/10/80 + 2/11/85 + 2/11/115 + 2/11/148 + 2/14/100 + 2/14/125 + 2/19/120
 Geschikte **reduceerringen** vindt u aan het einde van deze catalogus

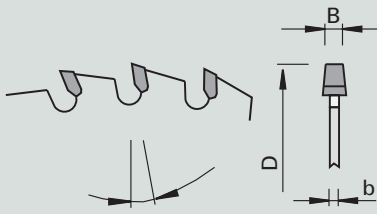
Producteigenschappen								Bestelinformatie				
Ø D [mm]	B [mm]	b [mm]	Ø d [mm]	Z	Snijkwaliteit*	NL**	Spaanhoek [°]		VE [St.]	V	ID - No	
480	4,8	3,5	30	72	▲▲▲	2/10/60 + 2/13/94	15	Schelling	●	1	S	50750139
480	4,8	3,5	60	72	▲▲▲	2/19/120	15	Holzma	●	1	S	50750140

HW RSK - nn-System Voorrits cirkelzaagbladen HW - conische-vlaktand

Product	Tekening	Machine	Toepassing	Uitvoering
				 3-0-1 HW TC04 plus KO-F

Machine / gebruiksaanwijzing	Uitvoering	Voordelen	Informatie - Tip
<ul style="list-style-type: none"> • Platenopdeelzagen met voorritsaggregaat • Voor het voorritsen van met kunststof beplakte plaatmaterialen 	<ul style="list-style-type: none"> • Speciale NoNoise-spaanruimtegeometrie • Tandvorm: conische-vlaktand 'KO-F' • Snijmateriaal HW TC04 plus 	<ul style="list-style-type: none"> • Snel verstelbaar • Universeel inzetbaar • Beste snijkwaliteit door verbeterde loopnauwkeurigheid volgens schema • Vermindering van de ritsdiepte • Extreem geluidsarm • Geluidsreducering met ca. 6 dB(A) bij stationair draaien • Zeer goede snijkwaliteit bij alle standaardcoatings • Lange standtijden zorgen voor de nodige productiviteit en rendabiliteit 	<ul style="list-style-type: none"> • Door hoogteverstelling van de as op snijbreedte van de hoofdzaag in te stellen • 1 mm ritsdiepte = 0,21 mm snijbreedte • Optimale voorrits-diepte 1,0 - 2,0 mm

Producteigenschappen								Bestelinformatie				
Ø D [mm]	B [mm]	b [mm]	Ø d [mm]	Z	Snijkwaliteit*	NL**	Spaanhoek [°]		VE [St.]	ID - No		
125	3,1-4,0	2,5	22	24	▲▲▲▲		8	Altendorf, Martin	●	1	58807954	
160	4,4-5,2	3,2	55	36	▲▲▲▲	3/7/66	8	Gabbiani	●	1	58803072	
180	4,4-5,2	3,2	30	30	▲▲▲▲	2/10/60	8	Panhans	●	1	58807858	
180	4,4-5,2	3,2	45	36	▲▲▲▲		8	Holzma	●	1	58803104	
180	4,85-5,65	3,5	45	36	▲▲▲▲		8	Holzma	●	1	58807862	
200	4,4-5,2	3,5	20	36	▲▲▲▲		8	Schelling	●	1	58803073	
200	4,4-5,2	3,5	45	36	▲▲▲▲		8	Homag	●	1	58803074	
200	4,85-5,65	3,5	45	36	▲▲▲▲		8	Homag	●	1	58806134	
200	4,45-5,25	3,2	65	36	▲▲▲▲	2/9/100 + 2/9/110	8	Selco	●	1	58806130	

* Snijkwaliteit ▲ Zeer grove snede, ▲▲ Grove snede, ▲▲▲ Fijne snede, ▲▲▲▲ Zeer fijne snede

** Extra gaten: Combi1 komt overeen met 2/10/60 + 2/7/42 Combi2 komt overeen met 2/7/42 + 2/9/46 en 2/10/60 Combi3 = 2/10/60 + 2/9/46 + 2/9,5/46,5 + 2/7/42 Combi5 = 2/7/110 + 2/9/110 + 2/8,4/130 + 2/14/110 + 4/9/100 + 4/19/120 Combi7 = 2/9/110 + 2/10/80 + 2/11/85 + 2/11/115 + 2/11/148 + 2/14/100 + 2/14/125 + 2/19/120

Geschikte reduceerringen vindt u aan het einde van deze catalogus

DP RSK
Voorrits cirkelzaagbladen DP - conische-vlaktand KO-F

Product



Tekening

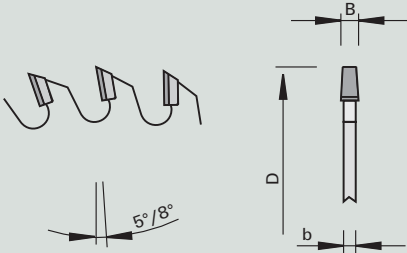

Machine



Toepassing



Uitvoering



4,5 mm

3-0-1

KO-F

- | | | | |
|---|---|------------------|---|
| <p>Machine / gebruiksaanwijzing</p> <ul style="list-style-type: none"> • Platenopdeelzagen met voorritsaggregaat • Voor het voorritsen van beplakte plaatmaterialen | <p>Uitvoering</p> <ul style="list-style-type: none"> • Diamantsnijkmanten in gepolijste uitvoering • Tandvorm: conische-vlaktand 'KO-F' • Snijmateriaal: DP • Naslijpzone 4,5 mm • Stamblad gecoat | <p>Voordelen</p> | <p>Informatie - Tip</p> <ul style="list-style-type: none"> • Inzetten in meeloop |
|---|---|------------------|---|



Producteigenschappen								Bestelinformatie				
Ø D [mm]	B [mm]	b [mm]	Ø d [mm]	Z	Snijkwaliteit*	NL**	Spaanhoek [°]		VE [St.]	V	ID - No	
160	4,4-5,2	3,2	45	30	▲▲▲▲	3/11/70	5	Giben	1	S	50750121	
180	4,4-5,2	3,2	30	30	▲▲▲▲	2/10/60	5	Panhans	1	S	50750122	
180	4,4-5,2	3,2	45	30	▲▲▲▲		5	Holzma	1	S	50750123	
180	4,8-5,6	3,5	45	30	▲▲▲▲		5	Holzma	1	S	50750124	
200	4,4-5,2	3,2	20	30	▲▲▲▲		5	Schelling	1	S	50750125	
200	4,4-5,2	3,2	20	36	▲▲▲▲		8	Schelling	1	S	50750147	
200	4,8-5,6	3,5	45	30	▲▲▲▲		5	Holzma	1	S	50750127	
200	4,8-5,6	3,5	65	30	▲▲▲▲	2/8,4/110	5	Selco	1	S	50750126	

* Snijkwaliteit ▲ Zeer grove snede, ▲▲ Grove snede, ▲▲▲ Fijne snede, ▲▲▲▲ Zeer fijne snede
 ** Extra gaten: Combi1 komt overeen met 2/10/60 + 2/7/42 Combi2 komt overeen met 2/7/42 + 2/9/46 en 2/10/60 Combi3 = 2/10/60 + 2/9/46 + 2/9,5/46,5 + 2/7/42 Combi5 = 2/7/110 + 2/9/110 + 2/8,4/130 + 2/14/110 + 4/9/100 + 4/19/120 Combi7 = 2/9/110 + 2/10/80 + 2/11/85 + 2/11/115 + 2/11/148 + 2/14/100 + 2/14/125 + 2/19/120
 Geschikte reduceerringen vindt u aan het einde van deze catalogus

HW

RSK - WS

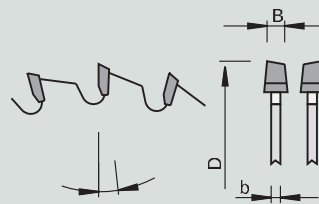
Voorrits cirkelzaagbladen HW - conische-wisseltand

Product	Tekening	Machine	Toepassing	Uitvoering
				3-0-1 HW TC04 plus KO-WS

Machine / gebruiksaanwijzing	Uitvoering	Voordelen	Informatie - Tip
<ul style="list-style-type: none"> • Platenopdeelzagen met voorritsaggregaat • Voor het voorritsen van met kunststof beplakte plaatmaterialen 	<ul style="list-style-type: none"> • Tandvorm: conische-wisseltand 'KO-WS' • Snijmateriaal HW TC04 plus 	<ul style="list-style-type: none"> • Kleinere motorbelasting door 'KO-WS'-tandvorm • Voor een langere standtijd in vergelijking met de TC03 plus • Beste snijkwaliteit door verbeterde loopnauwkeurigheid volgens schema • Vermindering van de ritsdiepte 	<ul style="list-style-type: none"> • Door hoogteverstelling van de as op snijbreedte van de hoofdzaag in te stellen • Optimale voorrits-diepte 1,0 - 2,0 mm

Producteigenschappen							Bestelinformatie			
Ø D [mm]	B [mm]	b [mm]	Ø d [mm]	Z	Snijkwaliteit*	Spaanhoek [°]	VE [St.]	V	ID - No	
180	4,45-5,25	3.2	30	30	▲▲▲	8		L	58807970	
300	4,45-5,25	3.2	30	48	▲▲▲	8		L	192751	

* Snijkwaliteit ▲ Zeer grove snede, ▲▲ Grove snede, ▲▲▲ Fijne snede, ▲▲▲▲ Zeer fijne snede

** Extra gaten: Combi1 komt overeen met 2/10/60 + 2/7/42 Combi2 komt overeen met 2/7/42 + 2/9/46 en 2/10/60 Combi3 = 2/10/60 + 2/9/46 + 2/9,5/46,5 + 2/7/42 Combi5 = 2/7/110 + 2/9/110 + 2/8,4/130 + 2/14/110 + 4/9/100 + 4/19/120 Combi7 = 2/9/110 + 2/10/80 + 2/11/85 + 2/11/115 + 2/11/148 + 2/14/100 + 2/14/125 + 2/19/120

Geschikte reduceerringen vindt u aan het einde van deze catalogus

HW

KKO - Kap/kantenverlijm

Afkortcirkelzaagbladen HW - wisseltand voor kantenbewerking zonder verzinking

Product

Tekening

Machine

Toepassing

Uitvoering

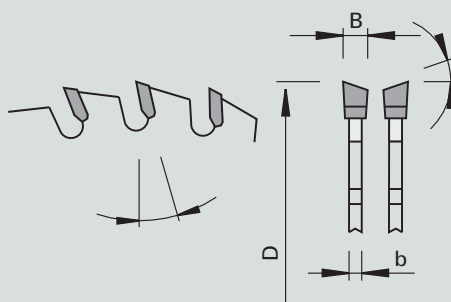

3-0-1

HW
TC06

WS

Machine / gebruiksaanwijzing

- Kantenaanlijmmachines
- Kantenbewerkingsautomaten
- Voor het afkorten van kantfineer op massief hout en fineer- en kunststofranden

Uitvoering

- Speciale NoNoise-spanruimte-geometrie
- Spaanhoek positief of negatief
- Met of zonder ashoek
- Tandvorm: wisseltand 'WS'
- Snijmateriaal HW TC06

Voordelen

- Extreem geluidsarm
- Geluidsreductie met ca. 6 dB(A) bij stationair draaien

Informatie - Tip

Producteigenschappen

Bestelinformatie

Ø D [mm]	B [mm]	b [mm]	Ø d [mm]	Z	Snijkwaliteit*	NL**	Spaanhoek [°]	Tandhoek [°]	Ashoek [°]		VE [St.]	V	ID - No
90	3,0	2,0	30	20	▲▲		8	10	0	Reich	1	L	192471
100	2,4	1,6	22	12	▲		15	10	5	HOLZ-HER	1	L	192472
100	2,4	1,6	22	20	▲▲	2/4/30	-8	10	5	EBM	1	L	58808802
100	3,2	2,2	22	20	▲▲▲		8	15	0	Felder	1	L	192475
100	2,6	1,6	32	30	▲▲		10	15	5	Brandt	1		192476
110	3,6	2,5	22	20	▲▲		8	30	5	HOLZ-HER, Reich	1	L	192477
110	3,6	2,5	32	20	▲▲		8	30	5	Homag	1	L	192478
120	3,2	2,2	32	20	▲▲		10	10	5	Homag	1	L	192483
125	2,4	1,6	32	24	▲▲		15	30	0	Brandt	1	L	192900
140	3,2	2,2	16	36	▲▲▲		10	15	5	Ott	1	L	192489
140	3,2	2,2	22	36	▲▲▲		10	15	5	HOLZ-HER	1	L	192488
150	3,2	2,2	22	48	▲▲▲		10	10	5	IMA	1	L	192493
160	3,2	2,2	20	48	▲▲▲		10	10	5	HOLZ-HER	1	L	192497
160	3,0	2,5	22	36	▲▲▲		-5	15	0	IMA	1	L	192456
160	3,5	2,5	22	36	▲▲▲		-5	15	5	IMA	1	L	188662
160	3,2	2,2	22	48	▲▲▲		-8	10	5	IMA	1	L	192498
160	3,2	2,2	30	24	▲▲	2/7/42	15	10	5	HOLZ-HER	1	L	192495
160	3,2	2,2	40	30	▲▲		-8	20	10	HOLZ-HER	1	L	192496
170	3,2	2,2	30	36	▲▲▲		10	20	0	Homag	1	L	193354
200	3,2	2,2	30	64	▲▲▲		10	15	0	IMA	1	L	192501

* Snijkwaliteit ▲ Zeer grove snede, ▲▲ Grove snede, ▲▲▲ Fijne snede, ▲▲▲▲ Zeer fijne snede





** Extra gaten: Combi1 komt overeen met 2/10/60 + 2/7/42 Combi2 komt overeen met 2/7/42 + 2/9/46 en 2/10/60 Combi3 = 2/10/60 + 2/9/46 + 2/9,5/46,5 + 2/7/42 Combi5 = 2/7/110 + 2/9/110 + 2/8,4/130 + 2/14/110 + 4/9/100 + 4/19/120 Combi7 = 2/9/110 + 2/10/80 + 2/11/85 + 2/11/115 + 2/11/148 + 2/14/100 + 2/14/125 + 2/19/120

Geschikte reduceerringen vindt u aan het einde van deze catalogus

HW

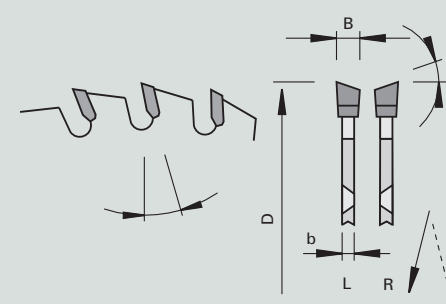
KKM - Kap/kantenverlijm

Afkortcirkelzaagbladen HW - wisseltand voor kantenbewerking met verzinking

<p>Product</p> 	<p>Tekening</p> 	<p>Machine</p> 	<p>Toepassing</p> 	<p>Uitvoering</p> 
--	--	--	---	---

<p>Machine / gebruiksaanwijzing</p> <ul style="list-style-type: none"> • Kantebewerkingsautomaten • Voor het afkorten van kantfijneer op massief hout en fineer- en kunststofranden 	<p>Uitvoering</p> <ul style="list-style-type: none"> • Speciale NoNoise-spaanruimte-geometrie • Spaanhoek positief • Met of zonder ashoek • Meeneemgaten verzonken • Tandvorm: wisseltand 'WS' • Snijmateriaal HW TC06 	<p>Voordelen</p> <ul style="list-style-type: none"> • Extreem geluidsarm 	<p>Informatie - Tip</p> <ul style="list-style-type: none"> • ID-No 192494 4NL/5,5/52 zijn zónder verzinking • Draairichting volgens VDMA 8849
---	--	---	---

Producteigenschappen												Bestelinformatie			
Ø D [mm]	B [mm]	b [mm]	Ø d [mm]	Z	Snijkwaliteit*	NL	Spaanhoek [°]	Tandhoek [°]	Ashoek [°]		L	VE [St]	V	ID - No	
110	3,2	2,5	40	20	▲▲▲	4/5,5/52	10	45	5	Homag	L	1	L	192480	
110	3,2	2,5	40	20	▲▲▲	4/5,5/52	10	45	5	Homag	R	1	L	192479	
120	3,6	2,8	40	24	▲▲	2x4/6/52	8	30	0	Homag	N	1	L	189751	
120	3,2	2,5	40	36	▲▲▲	2x4/5,5/52	10	45	5	Homag	N	1	L	192484	
125	2,4	1,6	30	36	▲▲▲	2x4/6,5/48	10	30	0	Homag BAZ	N	1	L	192487	
140	3,2	2,2	30	36	▲▲▲▲	4/8,6/46	10	15	5	Biesse Akron 600/800	L	1	O	192491	
140	3,2	2,2	30	36	▲▲▲	4/8,6/46	10	15	5	Biesse Akron 600/800	R	1	O	192490	
150	3,2	2,2	30	48	▲▲▲	4/6/48 + 4/5,5/52	10	15	0	Homag BAZ	R	1	L	192494	
180	3,2	2,2	30	54	▲▲▲	4/6/52	10	30	5	Homag BAZ	L	1	L	192500	

* Snijkwaliteit ▲ Zeer grove snede, ▲▲ Grove snede, ▲▲▲ Fijne snede, ▲▲▲▲ Zeer fijne snede

** Extra gaten: Combi1 komt overeen met 2/10/60 + 2/7/42 Combi2 komt overeen met 2/7/42 + 2/9/46 en 2/10/60 Combi3 = 2/10/60 + 2/9/46 + 2/9,5/46,5 + 2/7/42 Combi5 = 2/7/110 + 2/9/110 + 2/8,4/130 + 2/14/110 + 4/9/100 + 4/19/120 Combi7 = 2/9/110 + 2/10/80 + 2/11/85 + 2/11/115 + 2/11/148 + 2/14/100 + 2/14/125 + 2/19/120

Geschikte reduceerringen vindt u aan het einde van deze catalogus

HW

KKE - Kap/kantenverlijm

Afkortcirkelzaagbladen HW - eenzijdig spits voor kantenbewerking zonder verzinking

Product

Tekening

Machine

Toepassing

Uitvoering

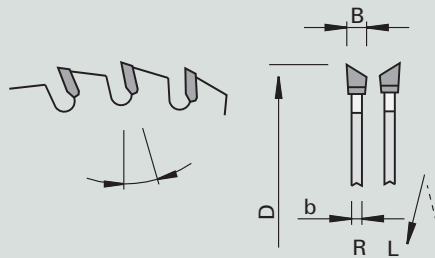

3-0-1

HW
TC06

ES

Machine / gebruiksaanwijzing

- Kantenaanlijmmachines
- Kantenbewerkingsautomaten
- Voor het afkorten van dunne kantfijner op massief hout en fijner- en kunststofranden

Uitvoering

- Speciale NoNoise-spaanruimtegeometrie
- Spaanhoek positief of negatief
- Met en zonder ashoek
- Tandvorm: eenzijdig spits 'ES' (rechts + links)*
- Snijmateriaal HW TC06

Voordelen

- Extreem geluidsarm

Informatie - Tip

- Draairichting zie tekening

Producteigenschappen

Bestelinformatie

Ø D [mm]	B [mm]	b [mm]	Ø d [mm]	Z	Snijkwaliteit*	NL**	Spaanhoek [°]	Tandhoek [°]	Ashoek [°]		L	VE [St.]	V	ID - No
100	2,6	2,0	32	30	▲▲		-10	15	0	Brandt	L	1	L	192510
100	2,6	2,0	32	30	▲▲		-10	15	0	Brandt	R	1	L	192509
100	2,6	2,0	32	30	▲▲		10	15	0	Homag CN	R	1	S	192513
100	2,6	1,6	32	30	▲▲		10	10	0	Brandt	L	1	L	192511
100	2,6	1,6	32	30	▲▲		10	10	0	Brandt	R	1	L	192512
150	3,5	2,2	30	44	▲▲▲	4/5,5/52	-12	45	10	Homag Powerline	L	1	L	192524
150	3,5	2,2	30	44	▲▲▲	4/5,5/52	-12	45	10	Homag Powerline	R	1	L	192523







* Snijkwaliteit ▲ Zeer grove snede, ▲▲ Grove snede, ▲▲▲ Fijne snede, ▲▲▲▲ Zeer fijne snede

** Extra gaten: Combi1 komt overeen met 2/10/60 + 2/7/42 Combi2 komt overeen met 2/7/42 + 2/9/46 en 2/10/60 Combi3 = 2/10/60 + 2/9/46 + 2/9,5/46,5 + 2/7/42 Combi5 = 2/7/110 + 2/9/110 + 2/8,4/130 + 2/14/110 + 4/9/100 + 4/19/120 Combi7 = 2/9/110 + 2/10/80 + 2/11/85 + 2/11/115 + 2/11/148 + 2/14/100 + 2/14/125 + 2/19/120

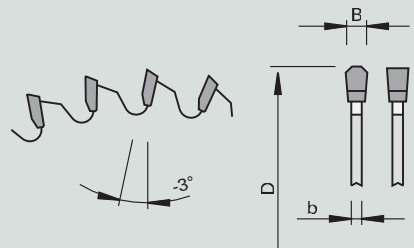
Geschikte reduceerringen vindt u aan het einde van deze catalogus

HW HKS - DS - Parat - negatief - Handcirkelzaagbladen

Universeel cirkelzaagbladen - negatieve spaanhoek trapezium-vlaktand, geschikt voor accumachines en netsnoer machines

<p>Product</p> 	<p>Tekening</p> 	<p>Machine</p>  	<p>Toepassing</p>   	<p>Uitvoering</p>  <p>2-0-6</p> <p>HW TC10</p> <p>TR-F</p>
--	--	--	---	---

<p>Machine / gebruiksaanwijzing</p> <ul style="list-style-type: none"> • Kap- en radiaal cirkelzagen • Handcirkelzagen • Voor vele toepassingsmogelijkheden en materialen (NE-metalen, volkern, kunststoffen(profielen) en volkern-materialen/ trespas) 	<p>Uitvoering</p> <ul style="list-style-type: none"> • Negatieve spaanhoek • Tandvorm: trapezium-vlaktand "TR-F" • Tandbezetting: HW TC10 • "DS" - Dünnschnitt (B=smal) 	<p>Voordelen</p> <ul style="list-style-type: none"> • Negatieve spaanhoek voor zuivere en mooie snijkwaliteit 	<p>Informatie - Tip</p> <ul style="list-style-type: none"> • Geschikt voor accumachines en netsnoer machines
--	---	--	---

Producteigenschappen						Bestelinformatie				
Ø D [mm]	B [mm]	b [mm]	Ø d [mm]	Z	Snijkwaliteit*		Spaanhoek [°]	VE [St.]	V	ID - No
160	1,8	1,2	20	52	▲▲▲▲	Makita, Mafell, Festool, Bosch	-3	1	L	58115607
165	1,8	1,2	20	52	▲▲▲▲	Makita, Dewalt, Bosch	-3	1	O	58115608
168	1,8	1,2	20	52	▲▲▲▲	Mafell, Festool	-3	1	L	58115609

* Snijkwaliteit ▲ Zeer grove snede, ▲▲ Grove snede, ▲▲▲ Fijne snede, ▲▲▲▲ Zeer fijne snede

** Extra gaten: Combi1 komt overeen met 2/10/60 + 2/7/42 Combi2 komt overeen met 2/7/42 + 2/9/46 en 2/10/60 Combi3 = 2/10/60 + 2/9/46 + 2/9,5/46,5 + 2/7/42 Combi5 = 2/7/110 + 2/9/110 + 2/8,4/130 + 2/14/110 + 4/9/100 + 4/19/120 Combi7 = 2/9/110 + 2/10/80 + 2/11/85 + 2/11/115 + 2/11/148 + 2/14/100 + 2/14/125 + 2/19/120

Geschikte reduceerringen vindt u aan het einde van deze catalogus

HW

Parat - negatief (HKS)

Universeel cirkelzaagbladen - negatieve spaanhoek trapezium-vlaktand

Product

Tekening

Machine

Toepassing

Uitvoering

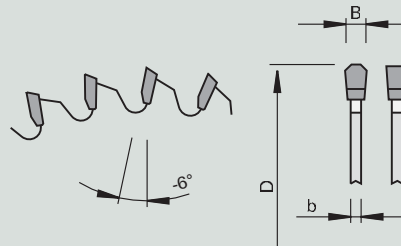

1-0-1
HW
TC10
TR-F

Machine / gebruiksaanwijzing

- Kap- en radiaal cirkelzagen
- Handcirkelzagen
- Voor vele toepassingsmogelijkheden en materialen NE-metalen, volkern, kunststoffen (profielen)

Uitvoering

- Negatieve spaanhoek
- Tandvorm: trapezium-vlaktand "TR-F"
- Tandbezetting: HW TC10

Voordelen

- Negatieve spaanhoek voor zuivere en mooie snijkwaliteit

Informatie - Tip

Producteigenschappen

Bestelinformatie

Ø D [mm]	B [mm]	b [mm]	Ø d [mm]	Z	Snijkwaliteit*	NL**	Spaanhoek [°]	VE [St.]	V	ID - No
130	2,8	2,2	20	36	▲▲		-6	1	O	58115027
150	2,8	2,2	20	42	▲▲	2/6/32,5	-6	1	L	58115002
160	2,2	1,6	20	42	▲▲	2/6/32,5	-6	1	L	58115004
160	2,2	1,6	20	56	▲▲▲	2/6/32,5	-6	1	L	58115042
160	2,8	2,2	30	42	▲▲	2/7/42	-6	1	L	58115026
165	2,4	1,6	20	48	▲▲	2/6/32,5	-6	1	O	58115044
180	2,8	2,2	20	48	▲▲	2/6/32,5	-6	1	L	58115007
180	2,8	2,2	30	48	▲▲	2/7/42	-6	1	L	58115008
190	2,8	2,2	20	54	▲▲	2/6/32,5	-6	1	L	58115009
190	2,6	2,0	20FX	58	▲▲	Fast-Fix	-6	1	L	58115033
190	2,8	2,2	30	54	▲▲	2/7/42	-6	1	L	58115010
200	2,8	2,2	30	54	▲▲	2/7/42	-6	1	L	58115011
210	2,8	2,2	30	54	▲▲	2/7/42	-6	1	L	58115012
216	2,8	2,2	30	60	▲▲	2/7/42	-6	1	L	58115024
216	2,8	2,2	30	80	▲▲▲	2/7/42	-6	1	L	58115034
220	2,8	2,2	30	54	▲▲	2/7/42	-6	1	L	58115021
225	2,8	2,2	30	60	▲▲	Combi3	-6	1	L	58115039
230	2,8	2,2	30	64	▲▲	2/7/42	-6	1	L	58115014

* Snijkwaliteit ▲ Zeer grove snede, ▲▲ Grove snede, ▲▲▲ Fijne snede, ▲▲▲▲ Zeer fijne snede





** Extra gaten: Combi1 komt overeen met 2/10/60 + 2/7/42 Combi2 komt overeen met 2/7/42 + 2/9/46 en 2/10/60 Combi3 = 2/10/60 + 2/9/46 + 2/9,5/46,5 + 2/7/42 Combi5 = 2/7/110 + 2/9/110 + 2/8,4/130 + 2/14/110 + 4/9/100 + 4/19/120 Combi7 = 2/9/110 + 2/10/80 + 2/11/85 + 2/11/115 + 2/11/148 + 2/14/100 + 2/14/125 + 2/19/120

Geschikte reduceerringen vindt u aan het einde van deze catalogus

HW

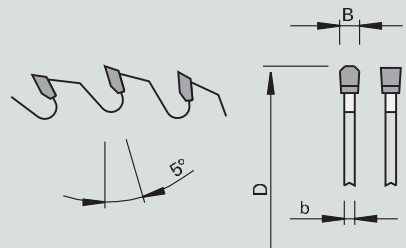
NE - Positief ALU

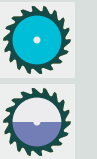
NE-cirkelzaagbladen HW - trapezium-vlaktand positieve spaanhoek

<p>Product</p> 	<p>Tekening</p> 	<p>Machine</p> 	<p>Toepassing</p> 	<p>Uitvoering</p>  <p>2-0-6</p> <p>3-0-1</p> <p>TR-F</p>
--	--	--	---	---

<p>Machine / gebruiksaanwijzing</p> <ul style="list-style-type: none"> • Tafelcirkelzagen • Afkort- en radiaalcirkelzagen • Voor formatteer- en versteeksnedes in aluminium, kunststofprofielen, aluminiumplaten bij machines met werkstuk opspanning en voor plaatmateriaal op basis van hout(Corian®, Noblan, Varicor® en HPL) 	<p>Uitvoering</p> <ul style="list-style-type: none"> • Spaanhoek positief • Tandvorm: trapezium-vlaktand 'TR-F' • Kwaliteit 2-0-6 tot Ø 349 • Kwaliteit 3-0-1 vanaf Ø 350 • Snijmateriaal: HW TC10 tot Ø 349 • Snijmateriaal: HW TC06 vanaf Ø 350 	<p>Voordelen</p> <ul style="list-style-type: none"> • Geluidsreductie door laserornamenten 	<p>Informatie - Tip</p> <ul style="list-style-type: none"> • Goede opspanning van het werkstuk vereist
---	---	---	---

Producteigenschappen										Bestelinformatie			
Ø D [mm]	B [mm]	b [mm]	Ø d [mm]	Z	Snijkwaliteit*	NL**	Spaanhoek [°]	Snijmateriaal		VE [St.]	V	ID - No	
250	3,2	2,5	30	80	▲▲	Combi3	5	TC10		1	L	58808102	
300	3,2	2,5	30	72	▲▲	Combi3	5	TC10		1	L	58808104	
300	3,2	2,5	30	96	▲▲▲	Combi3	5	TC10		1	L	58808107	
300	3,2	2,5	32	96	▲▲▲	4/12/64 + Combi3	5	TC10		1	O	58808125	
350	3,2	2,5	30	108	▲▲▲	Combi3	5	TC06		1	L	58808111	
400	3,8	3,2	30	96	▲▲	Combi3	5	TC06		1	L	58808113	
420	3,8	3,2	30	96	▲▲	Combi3	5	TC06		1	L	58808115	
500	4,0	3,4	30	120	▲▲▲	4/12/64 + 2/10/60	5	TC06		1	L	58808118	

* Snijkwaliteit ▲ Zeer grove snede, ▲▲ Grove snede, ▲▲▲ Fijne snede, ▲▲▲▲ Zeer fijne snede

** Extra gaten: Combi1 komt overeen met 2/10/60 + 2/7/42 Combi2 komt overeen met 2/7/42 + 2/9/46 en 2/10/60 Combi3 = 2/10/60 + 2/9/46 + 2/9,5/46,5 + 2/7/42 Combi5 = 2/7/110 + 2/9/110 + 2/8,4/130 + 2/14/110 + 4/9/100 + 4/19/120 Combi7 = 2/9/110 + 2/10/80 + 2/11/85 + 2/11/115 + 2/11/148 + 2/14/100 + 2/14/125 + 2/19/120

Geschikte reduceerringen vindt u aan het einde van deze catalogus

HW

NE - Negatief ALU

NE-kapcirkelzaagbladen HW - trapezium-vlaktand negatieve spaanhoek

Product

Tekening

Machine

Toepassing

Uitvoering

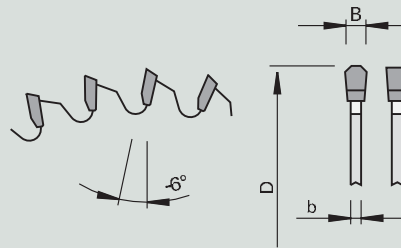

2-0-6

3-0-1

HW
TC06

HW
TC10

TR-
F

Machine / gebruiksaanwijzing

- Kap- en radiaalcirkelzagen
- Voor het afkorten en verstekzagen van aluminium- en kunststof profielen

Uitvoering

- Spaanhoek negatief
- Tandvorm: trapezium-vlaktand 'TR-F'
- Kwaliteit 2-0-6 tot Ø 349
- Kwaliteit 3-0-1 vanaf Ø 350
- Snijmateriaal: HW TC10 tot Ø 349
- Snijmateriaal: HW TC06 vanaf Ø 350

Voordelen

- Geluidsreductie door laserornamenten

Informatie - Tip

Producteigenschappen

Bestelinformatie

Ø D [mm]	B [mm]	b [mm]	Ø d [mm]	Z	Snijkwaliteit*	NL**		Spaanhoek [°]	VE [St.]	V	ID - No
235	2,8	2,2	30	64	▲▲	2/7/42		-6	1	L	58115018
250	3,2	2,5	30	60	▲▲	Combi3		-6	1	L	58808201
250	2,8	2,2	30	80	▲▲▲	Combi3		-6	1	L	58808200
250	3,2	2,5	30	80	▲▲▲	Combi3		-6	1	L	58808203
250	3,2	2,5	32	80	▲▲▲	Combi3		-6	1	L	58808204
250	3,2	2,5	40	80	▲▲▲	4/12/64 + 2/9/55 + Combi3		-6	1	O	58808205
254	2,4	1,8	30	60	▲▲	Combi3	Festool	-6	1	L	58808240
254	3,2	2,5	30	80	▲▲▲	Combi3		-6	1	L	58808246
260	3,2	2,5	30	72	▲▲	Combi3		-6	1	L	58808206
260	2,4	1,8	30	80	▲▲▲	Combi3		-6	1	L	58808260
280	3,2	2,5	30	64	▲▲▲	Combi3		-6	1	L	58808261
300	3,2	2,5	30	72	▲▲	Combi3		-6	1	L	58808209
300	2,8	2,2	30	96	▲▲▲	Combi3		-6	1	L	58808213
300	3,2	2,5	30	96	▲▲▲	Combi3		-6	1	L	58808214
300	3,2	2,5	32	96	▲▲▲	4/12/64		-6	1	L	58808215
300	3,3	2,5	40	96	▲▲▲	4/12/64 + 2/9/55		-6	1	L	58808216
305	3,2	2,5	30	60	▲▲	Combi3		-6	1	L	58808241
305	3,2	2,5	30	96	▲▲▲	Combi3		-6	1	L	58808245
315	3,2	2,5	30	96	▲▲▲	Combi3		-6	1	L	58808315
330	3,2	2,5	30	96	▲▲▲	Combi3		-6	1	L	58808217
330	3,2	2,5	32	96	▲▲▲	Combi3		-6	1	O	58808218
350	3,2	2,5	30	90	▲▲	Combi3		-6	1	L	58808222
350	3,2	2,5	30	108	▲▲▲	Combi3		-6	1	L	58808225
350	3,2	2,5	32	108	▲▲▲	4/12/64		-6	1	L	58808226
350	3,2	2,5	40	108	▲▲	4/12/64 + 2/9/55		-6	1	O	58808227
380	3,8	3,2	32	110	▲▲▲	4/12/64		-6	1	L	58808243
400	3,8	3,2	30	96	▲▲	Combi3		-6	1	L	58808232
420	4,0	3,2	30	96	▲▲	Combi3		-6	1	L	58808234
420	3,8	3,2	40	100	▲▲▲	4/12/64 + 2/9/55		-6	1	L	58808236

* Snijkwaliteit ▲ Zeer grove snede, ▲▲ Grove snede, ▲▲▲ Fijne snede, ▲▲▲▲ Zeer fijne snede

** Extra gaten: Combi1 komt overeen met 2/10/60 + 2/7/42 Combi2 komt overeen met 2/7/42 + 2/9/46 en 2/10/60 Combi3 = 2/10/60 + 2/9/46 + 2/9,5/46,5 + 2/7/42 Combi5 = 2/7/110 + 2/9/110 + 2/8,4/130 + 2/14/110 + 4/9/100 + 4/19/120 Combi7 = 2/9/110 + 2/10/80 + 2/11/85 + 2/11/115 + 2/11/148 + 2/14/100 + 2/14/125 + 2/19/120

Geschikte reduceerringen vindt u aan het einde van deze catalogus

Producteigenschappen							Bestelinformatie				
Ø D [mm]	B [mm]	b [mm]	Ø d [mm]	Z	Snijkwaliteit*	NL**	Spaanhoek [°]	VE [St.]	V	ID - No	
450	3,8	3,2	30	96	▲▲	4/12/64 + 2/12/80 + Combi3	-6	1	L	58808235	
500	4,0	3,4	30	120	▲▲▲	4/12/64 + 2/10/60	-6	1	L	58808239	

HW NE - Positief - Profiel 'G7'

NE-cirkelzaagbladen HW - 'G7' groepsvertanding positieve spaanhoek

Product



Tekening

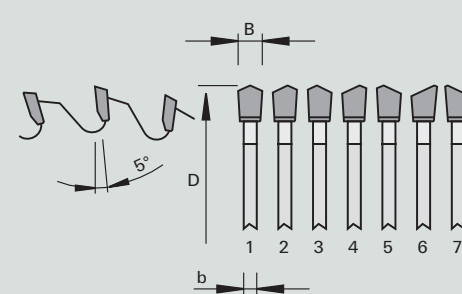

Machine



Toepassing



Uitvoering

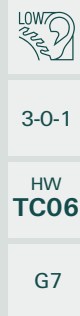

Machine / gebruiksaanwijzing

- Tafelcirkelzagen
- Voor braamvrije en gladde snedes in dunwandige aluminium kozijnen en gevelprofielen alsook PVC-profielen

Uitvoering

- Spaanhoek positief
- Tandvorm: 'G7'
- Snijmateriaal HW TC06

Voordelen

- Verminderen snijdruk door groepsvertanding 'G7'
- Uitstekende snedes met geringe ruwheidsdiepte door speciale tandplitsing
- Extreem geluidsarm door speciale laserornamenten
- Langere standtijd in vergelijking met cirkelzaagbladen met tandvorm 'TR-F'
- Betere prestaties en rendabiliteit

Informatie - Tip

- Goede werkstukopspanning vereist
- Wanddikte max. 5 mm

Producteigenschappen							Bestelinformatie				
Ø D [mm]	B [mm]	b [mm]	Ø d [mm]	Z	Snijkwaliteit*	NL	Spaanhoek [°]	VE [St.]	V	ID - No	
300	3,2	2,5	30	98	▲▲▲▲	2/7/42 + 2/9/46 + 2/10/60 + 2/11/70	5	1	L	192663	
350	3,2	2,5	30	98	▲▲▲▲	2/7/42 + 2/9/46 + 2/10/60	5	1	L	192662	
400	3,8	3,2	30	98	▲▲▲▲	2/7/42 + 2/9/46 + 2/10/60 + 2/15/80 + 4/12/64	5	1	L	192659	
420	3,8	3,2	30	98	▲▲▲▲		5	1	L	192660	
500	4,0	3,4	30	126	▲▲▲▲	2/7/42 + 2/9/46 + 2/10/60 + 2/10/70 + 4/12/64	5	1	L	192661	

* Snijkwaliteit ▲ Zeer grove snede, ▲▲ Grove snede, ▲▲▲ Fijne snede, ▲▲▲▲ Zeer fijne snede
 ** Extra gaten: Combi1 komt overeen met 2/10/60 + 2/7/42 Combi2 komt overeen met 2/7/42 + 2/9/46 en 2/10/60 Combi3 = 2/10/60 + 2/9/46 + 2/9,5/46,5 + 2/7/42 Combi5 = 2/7/110 + 2/9/110 + 2/8,4/130 + 2/14/110 + 4/9/100 + 4/19/120 Combi7 = 2/9/110 + 2/10/80 + 2/11/85 + 2/11/115 + 2/11/148 + 2/14/100 + 2/14/125 + 2/19/120
 Geschikte reduceerringen vindt u aan het einde van deze catalogus

HW NE - Kap - Negatief - Profiel 'G7'

NE-kapcirkelzaagbladen HW - 'G7' groepsvertanding negatieve spaanhoek

Product



Tekening

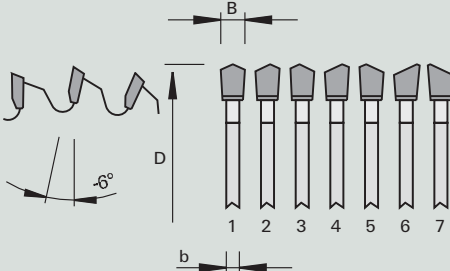

Machine



Toepassing



Uitvoering



3-0-1

HW
TC06

G7





<p>Machine / gebruiksaanwijzing</p> <ul style="list-style-type: none"> • Kap- en radiaal cirkelzagen • Voor kap- en versteksnedes in PVC-profielen • Voor braamvrije en gladde snedes in dunwandige aluminium kozijnen en gevelprofielen 	<p>Uitvoering</p> <ul style="list-style-type: none"> • Spaanhoek negatief • Tandvorm: 'G7' • Snijmateriaal HW TC06 	<p>Voordelen</p> <ul style="list-style-type: none"> • Verminderen snijdruk door groepsvertanding 'G7' • Uitstekende snedes met geringe ruwheidsdiepte door speciale tandsplitsing • Extreem geluidsarm door speciale laserornamenten • Langere standtijd in vergelijking met kapcirkelzaagbladen met tandvorm 'TR-F' • Betere prestaties en rendabiliteit 	<p>Informatie - Tip</p> <ul style="list-style-type: none"> • Goede werkstukopspanning vereist • Wanddikte max. 5 mm
---	---	--	---

Producteigenschappen								Bestelinformatie			
Ø D [mm]	B [mm]	b [mm]	Ø d [mm]	Z	Snijkwaliteit*	NL	Spaanhoek [°]		VE [St.]	V	ID - No
250	3,2	2,5	30	84	▲▲▲▲	2/7/42 + 2/9/46 + 2/9,5/46,5 + 2/10/60	-6		1	L	192965
300	3,2	2,5	30	98	▲▲▲▲	2/7/42 + 2/9/46 + 2/10/60 + 2/11/70	-6		1	L	192568
350	3,5	2,8	30	98	▲▲▲▲	2/7/42 + 2/9/46 + 2/9,5/46,5 + 2/10/60	-6	DeWALT, Haffner, Pfeiffer, Rotox	1	L	192274
350	3,2	2,5	30	112	▲▲▲▲	2/7/42 + 2/9/46 + 2/9,5/46,5 + 2/10/60	-6		1	L	58192275
350	3,8	3,2	40	84	▲▲▲▲	4/12/64 + 2/9/55	-6	Eisele LSM II, -LSM II-PV, -VA-L, Graule, Ulmia, Weidmann	1	L	192273
380	3,8	3,2	32	112	▲▲▲▲		-6	Elumatec	1	L	192567
400	3,8	3,2	30	98	▲▲▲▲	2/10/60 + 2/12/64 + 4/15/80	-6	DeWALT, Haffner	1	L	58192276
420	4,0	3,2	30	98	▲▲▲▲	2/10/60 + 2/11/70	-6	Rapid, ELU	1	L	192277
450	3,8	3,2	30	112	▲▲▲▲	2/10/60 + 2/12/64 + 4/15/80	-6	DeWALT, Haffner	1	L	58192278
500	4,0	3,4	30	126	▲▲▲▲	2/11/70 + 2/10/60	-6	Pfeiffer, Rapid	1	L	58192279
550	4,0	3,4	30	133	▲▲▲▲	2/10/60 + 2/12/64 + 4/15/80	-6	Pfeiffer, Rapid	1	L	58192392

* **Snijkwaliteit** ▲ Zeer grove snede, ▲▲ Grove snede, ▲▲▲ Fijne snede, ▲▲▲▲ Zeer fijne snede
 ** **Extra gaten: Combi1** komt overeen met 2/10/60 + 2/7/42 **Combi2** komt overeen met 2/7/42 + 2/9/46 en 2/10/60 **Combi3** = 2/10/60 + 2/9/46 + 2/9,5/46,5 + 2/7/42 **Combi5** = 2/7/110 + 2/9/110 + 2/8,4/130 + 2/14/110 + 4/9/100 + 4/19/120 **Combi7** = 2/9/110 + 2/10/80 + 2/11/85 + 2/11/115 + 2/11/148 + 2/14/100 + 2/14/125 + 2/19/120
 Geschikte **reduceerringen** vindt u aan het einde van deze catalogus

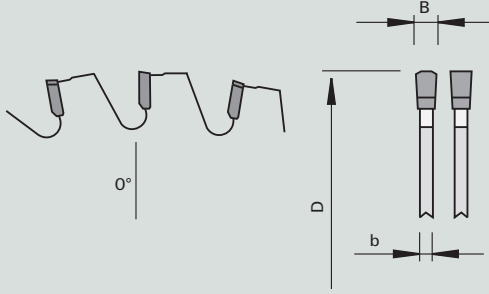
HW HKS - DS - Unisteel - Handcirkelzaagbladen

Handcirkelzaagbladen HW - trapezium-vlaktand, geschikt voor accumachines en netsnoer machines

Product	Tekening	Machine	Toepassing	Uitvoering
				  2-0-6 HW TCm13 TR-F

Machine / gebruiksaanwijzing	Uitvoering	Voordelen	Informatie - Tip
<ul style="list-style-type: none"> • Handcirkelzagen • Voor doorsnijden van metalen en non-ferro-metalen (zink), gietijzer enz. 	<ul style="list-style-type: none"> • Tandvorm: trapezium met vlaktand 'TR-F' • Snijmateriaal: HW TCm13 • "DS" - Dünnschnitt (B=smal) 	<ul style="list-style-type: none"> • Geringere vermogensopname door gereduceerde snijbreedte 	<ul style="list-style-type: none"> • Geschikt voor accumachines en netsnoer machines

Producteigenschappen						Bestelinformatie					
Ø D [mm]	B [mm]	b [mm]	Ø d [mm]	Z	Snijkwaliteit*		Spaanhoek [°]		VE [St.]	V	ID - No
136	1,6	1,2	20	36	▲▲	Dewalt	0		1	L	58116400
160	1,8	1,2	20	40	▲▲	Mafell, Festool	0		1	O	58116402
165	1,8	1,2	15,88	48	▲▲	Milwaukee	0		1	O	58116403
165	1,8	1,2	20	40	▲▲	Makita, Dewalt	0		1	L	58116401





* Snijkwaliteit ▲ Zeer grove snede, ▲▲ Grove snede, ▲▲▲ Fijne snede, ▲▲▲▲ Zeer fijne snede

** Extra gaten: Combi1 komt overeen met 2/10/60 + 2/7/42 Combi2 komt overeen met 2/7/42 + 2/9/46 en 2/10/60 Combi3 = 2/10/60 + 2/9/46 + 2/9,5/46,5 + 2/7/42 Combi5 = 2/7/110 + 2/9/110 + 2/8,4/130 + 2/14/110 + 4/9/100 + 4/19/120 Combi7 = 2/9/110 + 2/10/80 + 2/11/85 + 2/11/115 + 2/11/148 + 2/14/100 + 2/14/125 + 2/19/120

Geschikte reduceerringen vindt u aan het einde van deze catalogus

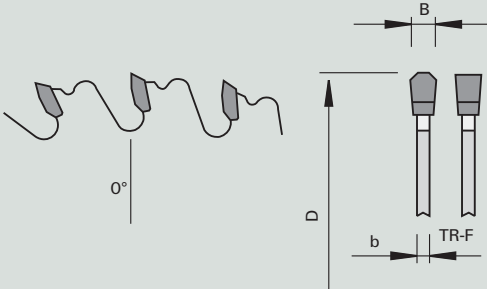
HW HKS - DS - Mega-Steel Handcirkelzaagbladen

Metaalcirkelzaagbladen HW - spaanhoek neutraal, geschikt voor accumachines en netsnoer machines

<p>Product</p> 	<p>Tekening</p> 	<p>Machine</p> 	<p>Toepassing</p> 	<p>Uitvoering</p>  <p>3-0-1</p> <p>HW TCx03</p> <p>TR-F</p>
--	--	--	---	--

- | | | | |
|---|---|---|---|
| <p>Machine / gebruiksaanwijzing</p> <ul style="list-style-type: none"> • Dry-cut (Droogzaag) machines • Universeel metaalzaagmachines • Voor zaagsneden in samengestelde materialen, edelstaal, lood, kunststoffen, Ne-materialen, kabelgoten, kabel, profielen, SML-buis etc. | <p>Uitvoering</p> <ul style="list-style-type: none"> • Tandvorm: trapezium-vlaktand 'TR-F' • Snijmateriaal: HT TCx03 • "DS" - Dünnschnitt (B=smal) | <p>Voordelen</p> <ul style="list-style-type: none"> • Droog zagen • Optimale snijkwaliteit • Extreem lange standtijd | <p>Informatie - Tip</p> <ul style="list-style-type: none"> • Geschikt voor accumachines en netsnoer machines • alt. Parat - Negativ (HKS) en Unisteel (HKS) |
|---|---|---|---|

Producteigenschappen						Bestelinformatie				
Ø D [mm]	B [mm]	b [mm]	Ø d [mm]	Z	Snijkwaliteit*		Spaanhoek [°]	VE [St.]	V	ID - No
150	1,8	1,4	20	32	▲▲	Makita, Bosch, Ryobi	10	1	L	58458810
160	1,8	1,4	20	40	▲▲	Mafell, Festool	0	1	L	58458784
190	1,8	1,4	30	48	▲▲	Hilti, Milwaukee, Dewalt	10	1	L	58458785
216	1,8	1,4	30	56	▲▲	Dewalt	0	1	L	58458786
230	1,8	1,4	30	60	▲▲		0	1	L	58805879

Aanbevolen omwentelingen per minuut (RPM):





- Ø160 = 2750 min-1
- Ø190 = 2350 min-1
- Ø216 = 2050 min-1
- Ø230 = 1950 min-1

* Snijkwaliteit ▲ Zeer grove snede, ▲▲ Grove snede, ▲▲▲ Fijne snede, ▲▲▲▲ Zeer fijne snede

** Extra gaten: Combi1 komt overeen met 2/10/60 + 2/7/42 Combi2 komt overeen met 2/7/42 + 2/9/46 en 2/10/60 Combi3 = 2/10/60 + 2/9/46 + 2/9,5/46,5 + 2/7/42 Combi5 = 2/7/110 + 2/9/110 + 2/8,4/130 + 2/14/110 + 4/9/100 + 4/19/120 Combi7 = 2/9/110 + 2/10/80 + 2/11/85 + 2/11/115 + 2/11/148 + 2/14/100 + 2/14/125 + 2/19/120

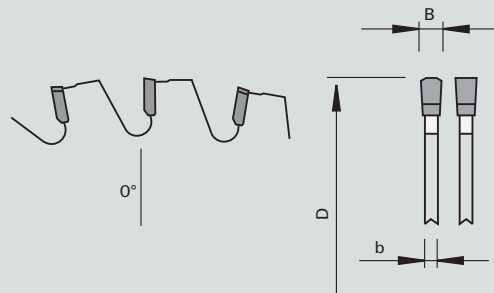
Geschikte reduceerringen vindt u aan het einde van deze catalogus

HW Unisteel (HKS)
NE-afkortcirkelzaagbladen HW - spaanhoek neutraal trapezium-vlaktand

<p>Product</p> 	<p>Tekening</p> 	<p>Machine</p> 	<p>Toepassing</p> 	<p>Uitvoering</p>  <p>2-0-6</p> <p>HW TCm13</p> <p>TR- F</p>
--	--	--	---	---

<p>Machine / gebruiksaanwijzing</p> <ul style="list-style-type: none"> • Kap- en radiaal cirkelzagen • Voor zaagsneden in metalen en NE-metalen, (zink), lood, gietijzer, etc. 	<p>Uitvoering</p> <ul style="list-style-type: none"> • Tandvorm: trapezium-vlaktand "TR-F" • Tandbezetting: HW TCm13 	<p>Voordelen</p> <ul style="list-style-type: none"> • Verbeterde snijkwaliteit door speciale tandgeometrie 	<p>Informatie - Tip</p> <ul style="list-style-type: none"> • Voor plaatmaterialen en kunststoffen zie ZWS en Parat-negatief (HKS) • Kleinere standtijd bij edelstalen
--	--	---	---

Producteigenschappen								Bestelinformatie			
Ø D [mm]	B [mm]	b [mm]	Ø d [mm]	Z	Snijkwaliteit*	NL**	Spaanhoek [°]	VE [St.]	V	ID - No	
150	2,2	1,6	20	30	▲▲	2/6/32,5	0	1	L	58116502	
160	2,2	1,6	20	30	▲▲	2/6/32,5	0	1	L	58116504	
180	2,2	1,6	20	36	▲▲	2/6/32,5	0	1	L	58116507	
180	2,2	1,6	30	36	▲▲	2/7/42	0	1	L	58116508	
190	2,4	1,8	20	38	▲▲	2/6/32,5	0	1	L	58116509	
190	2,4	1,8	30	38	▲▲	Combi3	0	1	L	58116510	
210	2,4	1,8	30	40	▲▲	2/7/42	0	1	L	58116512	
216	2,4	1,8	30	40	▲▲	2/7/42	0	1	L	58116520	
230	2,4	1,8	30	44	▲▲	2/7/42	0	1	L	58116514	
235	2,4	1,8	30	44	▲▲	2/7/42	0	1	L	58116521	
240	2,4	1,8	30	44	▲▲	Combi3	0	1	L	58116515	

* Snijkwaliteit ▲ Zeer grove snede, ▲▲ Grove snede, ▲▲▲ Fijne snede, ▲▲▲▲ Zeer fijne snede





** Extra gaten: Combi1 komt overeen met 2/10/60 + 2/7/42 Combi2 komt overeen met 2/7/42 + 2/9/46 en 2/10/60 Combi3 = 2/10/60 + 2/9/46 + 2/9,5/46,5 + 2/7/42 Combi5 = 2/7/110 + 2/9/110 + 2/8,4/130 + 2/14/110 + 4/9/100 + 4/19/120 Combi7 = 2/9/110 + 2/10/80 + 2/11/85 + 2/11/115 + 2/11/148 + 2/14/100 + 2/14/125 + 2/19/120

Geschikte reduceerringen vindt u aan het einde van deze catalogus

HW

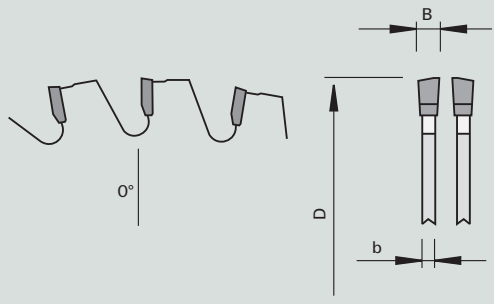
Unisteel

Metaal-afkortcirkelzaagbladen HW - vlakland met wissel fase spaanhoek neutraal

<p>Product</p> 	<p>Tekening</p> 	<p>Machine</p> 	<p>Toepassing</p> 	<p>Uitvoering</p>  <p>3-0-1</p> <p>HW TCm13</p> <p>F-WFA</p>
--	--	--	---	---

<p>Machine / gebruiksaanwijzing</p> <ul style="list-style-type: none"> • Tafelcirkelzagen • Kap- en radiaal cirkelzagen • voor zaagsneden in metalen en NE-metalen, (zink), lood, gietijzer, etc. 	<p>Uitvoering</p> <ul style="list-style-type: none"> • Tandvorm: vlakland met wissel fase 'F-WFA' • Snijmateriaal: HW TCm 13 	<p>Voordelen</p> <ul style="list-style-type: none"> • Verbeterde snijkwaliteit door speciale tandgeometrie 	<p>Informatie - Tip</p> <ul style="list-style-type: none"> • Voor plaatmaterialen en kunststoffen zie ZWS en Parat-negatief (HKS) • Kleinere standtijd bij edelstalen
--	--	---	---

Producteigenschappen								Bestelinformatie			
Ø D [mm]	B [mm]	b [mm]	Ø d [mm]	Z	Snijkwaliteit*	NL**	Spaanhoek [°]	VE [St.]	V	ID - No	
254	2,4	1,8	30	48	▲	Combi3	0		1	L 58165001	
260	2,5	1,8	30	60	▲	Combi3	0		1	L 58165010	
270	2,6	2,2	30	54	▲▲	Combi3	0		1	L 58116517	
305	2,6	2,2	30	60	▲▲	Combi3	0		1	L 58165002	
330	2,6	2,2	30	54	▲	Combi3	0		1	L 58165005	
355	2,6	2,2	30	80	▲▲	Combi3	0		1	L 58165003	
400	2,6	2,2	30	84	▲▲	Combi3	0		1	L 58165004	
450	2,6	2,2	30	90	▲▲	Combi3	0		1	L 58165006	

Aanbevolen omwentelingen per minuut (RPM):

- Ø254 = 1750 min-1
- Ø305 = 1500 min-1
- Ø330 = 1350 min-1
- Ø355 = 1250 min-1





* Snijkwaliteit ▲ Zeer grove snede, ▲▲ Grove snede, ▲▲▲ Fijne snede, ▲▲▲▲ Zeer fijne snede

** Extra gaten: Combi1 komt overeen met 2/10/60 + 2/7/42 Combi2 komt overeen met 2/7/42 + 2/9/46 en 2/10/60 Combi3 = 2/10/60 + 2/9/46 + 2/9,5/46,5 + 2/7/42 Combi5 = 2/7/110 + 2/9/110 + 2/8,4/130 + 2/14/110 + 4/9/100 + 4/19/120 Combi7 = 2/9/110 + 2/10/80 + 2/11/85 + 2/11/115 + 2/11/148 + 2/14/100 + 2/14/125 + 2/19/120
Geschikte reduceerringen vindt u aan het einde van deze catalogus

HW

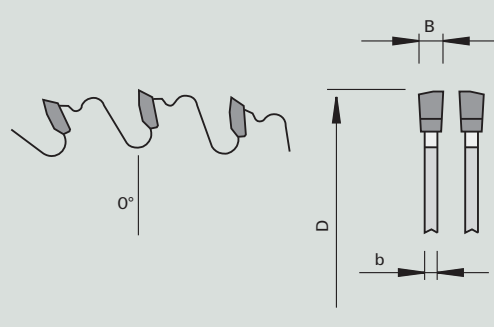
Steel

Metaal-afkortcirkelzaagbladen HW - vlakland met wissel fase spaanhoek neutraal

Product	Tekening	Machine	Toepassing	Uitvoering
				 3-0-1 HW TCm13 F- WFA

Machine / gebruiksaanwijzing	Uitvoering	Voordelen	Informatie - Tip
<ul style="list-style-type: none"> • Dry-cut (Droogzaag) machines • Universeel metaalzaagmachines • Voor zaagsneden in samengestelde materialen, lood, kunststoffen, Ne-materialen, kabelgoten, kabel, profielen, SML-buis etc. 	<ul style="list-style-type: none"> • Tandvorm: vlakland met wissel fase "F-WFA" • Tandbezetting: HW TCm13 	<ul style="list-style-type: none"> • Droog zagen • Optimale snijkwaliteit 	

Producteigenschappen							Bestelinformatie				
Ø D [mm]	B [mm]	b [mm]	Ø d [mm]	Z	Snijkwaliteit*	NL**	Spaanhoek [°]	VE [St.]	V	ID - No	
254	2,2	1,8	30	60	▲▲	Combi3	0	1	L	58805861	
305	2,2	1,8	25,4	60	▲▲		0	1	L	58805862	
305	2,2	1,8	25,4	80	▲▲		0	1	L	58805863	
305	2,2	1,8	30	80	▲▲▲	Combi3	0	1	L	58805864	
320	2,2	1,8	25,4	84	▲▲▲		0	1	L	58805859	
330	2,2	1,8	30	90	▲▲▲	Combi3	0	1	L	58805865	
355	2,2	1,8	25,4	80	▲▲▲		0	1	L	58805866	
355	2,2	1,8	25,4	90	▲▲▲		0	1	L	58805868	
355	2,2	1,8	30	90	▲▲▲	Combi3	0	1	L	58805867	

Aanbevolen omwentelingen per minuut (RPM):

- Ø254 = 1750 min-1
- Ø305 = 1500 min-1
- Ø330 = 1350 min-1
- Ø355 = 1250 min-1

* Snijkwaliteit ▲ Zeer grove snede, ▲▲ Grove snede, ▲▲▲ Fijne snede, ▲▲▲▲ Zeer fijne snede

** Extra gaten: Combi1 komt overeen met 2/10/60 + 2/7/42 Combi2 komt overeen met 2/7/42 + 2/9/46 en 2/10/60 Combi3 = 2/10/60 + 2/9/46 + 2/9,5/46,5 + 2/7/42 Combi5 = 2/7/110 + 2/9/110 + 2/8,4/130 + 2/14/110 + 4/9/100 + 4/19/120 Combi7 = 2/9/110 + 2/10/80 + 2/11/85 + 2/11/115 + 2/11/148 + 2/14/100 + 2/14/125 + 2/19/120

Geschikte reduceerringen vindt u aan het einde van deze catalogus

HW

Mega-Steel

Metaal-afkortcirkelzaagbladen HW - vlakland met wissel fase spaanhoek neutraal

Product



Tekening

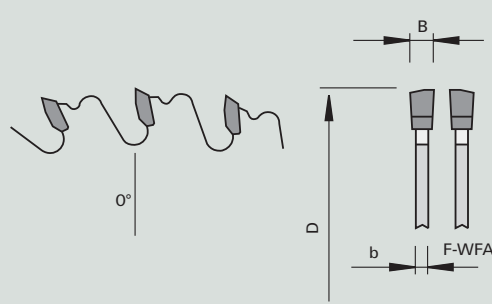

Machine



Toepassing



Uitvoering



3-0-1

HW
TCx03

F-
WFA

Machine / gebruiksaanwijzing

- Dry-cut (Droogzaag) machines
- Universeel metaalzaagmachines
- Voor zaagsneden in samengestelde materialen, edelstaal, lood, kunststoffen, Ne-materialen, kabelgoten, kabelprofielen, SML-buis etc.

Uitvoering

- Tandvorm: vlakland met wissel fase 'F-WFA'
- Snijmateriaal: HT TCx03

Voordelen

- Droog zagen
- Optimale snijkwaliteit
- Extreem lange standtijd

Informatie - Tip

- Voor kleinere maten adviseren we onze types Parat - Negativ, HKS Unisteel en HKS Mega-Steel

Producteigenschappen

Bestelinformatie

Ø D [mm]	B [mm]	b [mm]	Ø d [mm]	Z	Snijkwaliteit*	NL**	Spaanhoek [°]	Tandvorm	VE [St.]	V	ID - No
254	2,2	1,8	25,4	72	▲▲		0	F-WFA	1	L	58805870
254	2,2	1,8	30	72	▲▲	Combi3	0	F-WFA	1	L	58805871
305	2,2	1,8	25,4	60	▲▲		0	F-WFA	1	L	50805872
305	2,2	1,8	25,4	80	▲▲▲		0	F-WFA	1	L	50805873
305	2,2	1,8	30	80	▲▲▲	Combi3	0	F-WFA	1	L	50805874
355	2,2	1,8	25,4	80	▲▲▲		0	F-WFA	1	L	50805876
355	2,2	1,8	25,4	90	▲▲▲		0	F-WFA	1	L	50805878
355	2,2	1,8	30	90	▲▲▲	Combi3	0	F-WFA	1	L	50805877

Aanbevolen omwentelingen per minuut (RPM):

Ø254 = 1750 min-1

Ø305 = 1500 min-1

Ø355 = 1250 min-1

* Snijkwaliteit ▲ Zeer grove snede, ▲▲ Grove snede, ▲▲▲ Fijne snede, ▲▲▲▲ Zeer fijne snede

** Extra gaten: Combi1 komt overeen met 2/10/60 + 2/7/42 Combi2 komt overeen met 2/7/42 + 2/9/46 en 2/10/60 Combi3 = 2/10/60 + 2/9/46 + 2/9,5/46,5 + 2/7/42 Combi5 = 2/7/110 + 2/9/110 + 2/8,4/130 + 2/14/110 + 4/9/100 + 4/19/120 Combi7 = 2/9/110 + 2/10/80 + 2/11/85 + 2/11/115 + 2/11/148 + 2/14/100 + 2/14/125 + 2/19/120

Geschikte reduceerringen vindt u aan het einde van deze catalogus

HS Stoomontladen DMO-5

Metaal - afkortzaagbladen HS - voor gekoeld metaalzagen

Product



Tekening

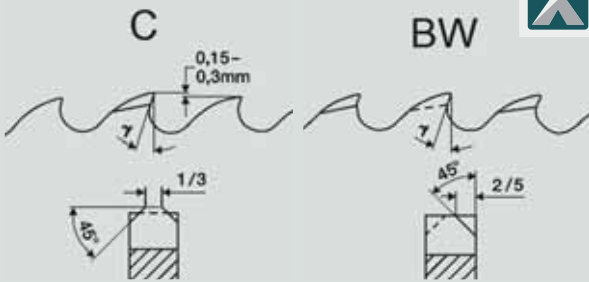

Machine



Toepassing



Uitvoering

BW

2-0-1

HS DMO5

- | | | | |
|--|--|--|---|
| <p>Machine / gebruiksaanwijzing</p> <ul style="list-style-type: none"> • Metaalmachines met koeling • Inzetbaar voor de meeste metalen | <p>Uitvoering</p> <ul style="list-style-type: none"> • Tandvormen: C, BW, HZ • Zaagblad massief DMO5 staal | <p>Voordelen</p> <ul style="list-style-type: none"> • Gekoeld metaalzagen voorkomt verbrandingsproces | <p>Informatie - Tip</p> <ul style="list-style-type: none"> • Kleine standtijd bij edelstalen |
|--|--|--|---|

Omschrijving/maatvoering [mm]	ID - No
200x1,8x32 Z=160/T=04,0 SOL	50139216
200x1,8x32 Z=200/T=03,0 SOL	50139419
200x2,0x32 Z=128/T=05,0 SOL	50139232
200x2,0x32 Z=160/T=04,0 SOL	50139420
200x2,0x32 Z=200/T=03,0 SOL	50139238
210x2,0x32 Z=160/T=04,0 SOL	50139478
225x2,0x32 Z=090/T=08,0 SOL	50139454
225x2,0x32 Z=120/T=06,0 SOL	50139414
225x2,0x32 Z=150/T=05,0 SOL	50139421
225x2,0x32 Z=160/T=04,5 SOL	50139415
225x2,0x32 Z=180/T=04,0 SOL	50139422
225x2,0x32 Z=220/T=03,0 SOL	50139451
225x2,0x40 Z=090/T=08,0 SOL	50139171
225x2,0x40 Z=120/T=06,0 SOL	50139449
225x2,0x40 Z=150/T=05,0 SOL	50139435
225x2,0x40 Z=180/T=04,0 SOL	50139436
225x2,0x40 Z=220/T=03,0 SOL	50139172
250x2,0x32 Z=080/T=10,0 SOL	50139471
250x2,0x32 Z=100/T=08,0 SOL	50139173
250x2,0x32 Z=128/T=06,0 SOL	50139417
250x2,0x32 Z=128/T=06,0 SOL/RVS	50139602
250x2,0x32 Z=160/T=05,0 SOL	50139423
250x2,0x32 Z=160/T=05,0 SOL/RVS	50139601
250x2,0x32 Z=180/T=04,5 SOL	50139459
250x2,0x32 Z=200/T=04,0 SOL	50139424
250x2,0x32 Z=200/T=04,0 SOL/RVS	50139600
250x2,0x32 Z=240/T=03,0 SOL	50139450
250x2,5x32 Z=100/T=08,0 SOL	50139455
250x2,5x32 Z=128/T=06,0 SOL	50139448
250x2,5x32 Z=160/T=05,0 SOL	50139465
250x2,5x32 Z=200/T=04,0 SOL	50139476
250x2,0x40 Z=100/T=08,0 SOL	50139170
250x2,0x40 Z=128/T=06,0 SOL	50139416
250x2,0x40 Z=160/T=05,0 SOL	50139425
250x2,0x40 Z=200/T=04,0 SOL	50139426
250x2,0x40 Z=240/T=03,0 SOL	50139466
250x2,5x40 Z=100/T=08,0 SOL	50139176
250x2,5x40 Z=128/T=06,0 SOL	50139175
250x2,5x40 Z=160/T=05,0 SOL	50139411
250x2,5x40 Z=200/T=04,0 SOL	50139410
275x2,0x32 Z=110/T=08,0 SOL	50139178
275x2,0x32 Z=144/T=06,0 SOL	50139179
275x2,0x32 Z=180/T=05,0 SOL	50139180
275x2,0x32 Z=220/T=04,0 SOL	50139477
275x2,0x32 Z=280/T=03,0 SOL	50139181
275x2,5x32 Z=110/T=08,0 SOL	50139187

Omschrijving/maatvoering [mm]	ID - No
275x2,5x32 Z=144/T=06,0 SOL	50139457
275x2,5x32 Z=180/T=05,0 SOL	50139427
275x2,5x32 Z=220/T=04,0 SOL	50139428
275x2,5x32 Z=280/T=03,0 SOL	50139188
275x2,0x40 Z=110/T=08,0 SOL	50139182
275x2,0x40 Z=144/T=06,0 SOL	50139183
275x2,0x40 Z=180/T=05,0 SOL	50139184
275x2,0x40 Z=220/T=04,0 SOL	50139185
275x2,0x40 Z=280/T=03,0 SOL	50139186
275x2,5x40 Z=110/T=08,0 SOL	50139189
275x2,5x40 Z=144/T=06,0 SOL	50139190
275x2,5x40 Z=180/T=05,0 SOL	50139437
275x2,5x40 Z=220/T=04,0 SOL	50139438
275x2,5x40 Z=280/T=03,0 SOL	50139191
300x2,5x32 Z=120/T=08,0 SOL	50139174
300x2,5x32 Z=160/T=06,0 SOL	50139461
300x2,5x32 Z=200/T=05,0 SOL	50139429
300x2,5x32 Z=240/T=04,0 SOL	50139430
300x2,5x40 Z=120/T=08,0 SOL	50139472
300x2,5x40 Z=160/T=06,0 SOL	50139413
300x2,5x40 Z=200/T=05,0 SOL	50139439
300x2,5x40 Z=240/T=04,0 SOL	50139440
315x2,5x32 Z=120/T=08,0 SOL	50139467
315x2,5x32 Z=160/T=06,0 SOL	50139501
315x2,5x32 Z=200/T=05,0 SOL	50139431
315x2,5x32 Z=250/T=04,0 SOL	50139432
315x3,0x32 Z=100/T=10,0 SOL	50139230
315x3,0x32 Z=120/T=08,0 SOL	50139192
315x3,0x32 Z=160/T=06,0 SOL	50139193
315x3,0x32 Z=200/T=05,0 SOL	50139468
315x3,0x32 Z=250/T=04,0 SOL	50139194
315x2,5x40 Z=080/T=12,0 SOL	50139508
315x2,5x40 Z=100/T=10,0 SOL	50139418
315x2,5x40 Z=120/T=08,0 SOL	50139462
315x2,5x40 Z=160/T=06,0 SOL	50139447
315x2,5x40 Z=200/T=05,0 SOL	50139433
315x2,5x40 Z=250/T=04,0 SOL	50139434
315x3,0x40 Z=080/T=12,0 SOL	50139195
315x3,0x40 Z=100/T=10,0 SOL	50139196
315x3,0x40 Z=120/T=08,0 SOL	50139197
315x3,0x40 Z=140/T=07,0 SOL	50139229
315x3,0x40 Z=160/T=06,0 SOL	50139198
315x3,0x40 Z=200/T=05,0 SOL	50139199
315x3,0x40 Z=250/T=04,0 SOL	50139200
350x2,5x32 Z=110/T=10,0 SOL	50139202
350x2,5x32 Z=140/T=08,0 SOL	50139203

Omschrijving/maatvoering [mm]	ID - No
350x2,5x32 Z=180/T=06,0 SOL	50139412
350x2,5x32 Z=220/T=05,0 SOL	50139350
350x2,5x32 Z=280/T=04,0 SOL	50139201
350x3,0x32 Z=110/T=10,0 SOL	50139218
350x3,0x32 Z=140/T=08,0 SOL	50139219
350x3,0x32 Z=180/T=06,0 SOL	50139473
350x3,0x32 Z=220/T=05,0 SOL	50139441
350x3,0x32 Z=280/T=04,0 SOL	50139442
350x2,5x40 Z=110/T=10,0 SOL	50139204
350x2,5x40 Z=140/T=08,0 SOL	50139205
350x2,5x40 Z=180/T=06,0 SOL	50139206
350x2,5x40 Z=220/T=05,0 SOL	50139207
350x2,5x40 Z=280/T=04,0 SOL	50139208
350x3,0x40 Z=110/T=10,0 SOL	50139220
350x3,0x40 Z=140/T=08,0 SOL	50139221
350x3,0x40 Z=160/T=07,0 SOL	50139222
350x3,0x40 Z=180/T=06,0 SOL	50139223
350x3,0x40 Z=220/T=05,0 SOL	50139443
350x3,0x40 Z=280/T=04,0 SOL	50139444
350x2,5x50 Z=100/T=11,0 SOL	50139209
350x2,5x50 Z=110/T=10,0 SOL	50139210
350x2,5x50 Z=120/T=09,0 SOL	50139211
350x2,5x50 Z=140/T=08,0 SOL	50139212
350x2,5x50 Z=160/T=07,0 SOL	50139213
350x2,5x50 Z=180/T=06,0 SOL	50139214

Omschrijving/maatvoering [mm]	ID - No
350x2,5x50 Z=220/T=05,0 SOL	50139215
350x2,5x50 Z=280/T=04,0 SOL	50139217
350x3,0x50 Z=100/T=11,0 SOL	50139224
350x3,0x50 Z=120/T=09,0 SOL	50139225
350x3,0x50 Z=160/T=07,0 SOL	50139226
350x3,0x50 Z=220/T=05,0 SOL	50139460
370x3,0x40 Z=120/T=09,0 SOL	50139227
370x3,0x40 Z=140/T=08,0 SOL	50139456
370x3,0x40 Z=160/T=07,0 SOL	50139464
370x3,0x40 Z=190/T=06,0 SOL	50139458
370x3,0x40 Z=280/T=04,0 SOL	50139228
370x3,0x50 Z=100/T=11,0 SOL	50139475
370x3,0x50 Z=120/T=09,0 SOL	50139452
370x3,0x50 Z=160/T=07,0 SOL	50139474
370x3,0x50 Z=220/T=05,0 SOL	50139453
400x3,5x40 Z=200/T=06,0 SOL	50139506
400x3,5x40 Z=230/T=05,0 SOL	50139445
400x3,5x40 Z=310/T=04,0 SOL	50139446
400x4,0x50 Z=96/T=13,0 SOL	68002249
400x3,0x50 Z=180/T=07,0 SOL	50139463
400x3,0x50 Z=200/T=06,0 SOL	50139503
450x4,0x40 Z=070/T=20,0 SOL	50139505
450x4,0x40 Z=090/T=16,0 SOL	50139504
450x3,5x40 Z=240/T=06,0 SOL	50139507

HSS Stoomontladen HSS/Cobalt

Metaal - afkortzaagbladen HS - voor gekoeld rvs/edelstaalzagen

Product



Tekening

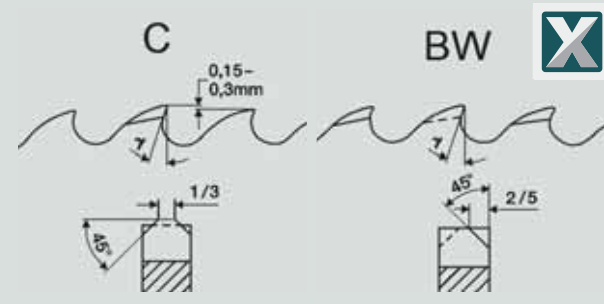

Machine



Toepassing



Uitvoering

BW

3-0-1



HSS Cobalt

- | | | | |
|---|--|--|--|
| <p>Machine / gebruiksaanwijzing</p> <ul style="list-style-type: none"> • Metaalmachines met koeling • Inzetbaar voor de meeste metalen • Edelstaal en andere hoogwaardige materialen | <p>Uitvoering</p> <ul style="list-style-type: none"> • Tandvormen: C, BW, HZ • Zaagblad massief HSS Cobalt | <p>Voordelen</p> <ul style="list-style-type: none"> • Gekoeld metaalzagen voorkomt verbrandingsproces | <p>Informatie - Tip</p> <ul style="list-style-type: none"> • Goede standtijd bij edelstalen |
|---|--|--|--|





Omschrijving/maatvoering [mm]	ID - No
225x2,0x32 Z=180/T=04,0 RVS/COB	68001433
250x2,0x32 Z=112/T=07,0 RVS/COB	68002184
250x2,0x32 Z=128/T=06,0 RVS/COB	68001817
250x2,0x32 Z=160/T=05,0 RVS/COB	68001661
250x2,0x32 Z=180/T=04,5 RVS/COB	68001639
250x2,0x32 Z=200/T=04,0 RVS/COB	68001332
250x2,0x32 Z=240/T=03,3 RVS/COB	68001697
250x2,5x32 Z=160/T=05,0 RVS/COB	68001646
250x2,5x32 Z=180/T=04,5 RVS/COB	68001490
250x2,0x40 Z=200/T=04,0 RVS/COB	68001486
275x2,0x32 Z=180/T=05,0 RVS/COB	68001565
275x2,5x40 Z=220/T=04,0 RVS/COB	68002195
300x2,5x32 Z=200/T=05,0 RVS/COB	68001454
300x2,5x40 Z=200/T=05,0 RVS/COB	68002290

Omschrijving/maatvoering [mm]	ID - No
315x2,5x32 Z=160/T=06,0 RVS/COB	68001662
315x2,5x32 Z=200/T=05,0 RVS/COB	68001663
315x2,5x40 Z=080/T=12,0 RVS/COB	68002100
315x2,5x40 Z=128/T=07,7 RVS/COB	68001845
315x2,5x40 Z=160/T=06,0 RVS/COB	68001616
315x2,5x40 Z=200/T=05,0 RVS/COB	68001672
315x2,5x40 Z=250/T=04,0 RVS/COB	68000814
315x2,5x40 Z=280/T=03,5 RVS/COB	68000735
350x2,5x32 Z=280/T=04,0 RVS/COB	68001843
350x3,0x32 Z=280/T=04,0 RVS/COB	68002177
350x3,0x40 Z=160/T=07,0 RVS/COB	68000354
350x3,0x40 Z=220/T=05,0 RVS/COB	68002166
370x3,0x40 Z=190/T=06,0 RVS/COB	68000368
370x3,0x40 Z=220/T=05,0 RVS/COB	68002284



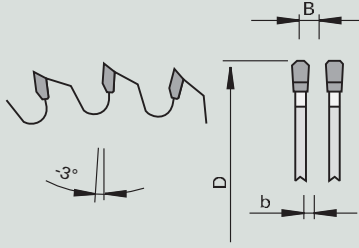

HW

HKS - DS - KKT - Hard plastic negatief - Handcirkelzaagbladen

Handcirkelzaagblad HW voor zeer harde kunststofprofielen - trapezium-vlaktand met tweezijdige fase, geschikt voor accumachines en netsnoer machines

Product	Tekening	Machine	Toepassing	Uitvoering
				 3-0-1 HW TC04 plus TR-F-FA

Machine / gebruiksaanwijzing	Uitvoering	Voordelen	Informatie - Tip
<ul style="list-style-type: none"> • Handcirkelzagen • voor zaagsneden in kunststof profielen van bijv. Corian®, Varicor®, Trespa®, laminaat, etc. 	<ul style="list-style-type: none"> • Spaanhoek negatief • Tandvorm: trapezium-vlaktand met tweezijdige fase 'TR-F-FA' • Snijmateriaal HW TC04 plus • "DS" - Dünnschnitt (B=smal) 	<ul style="list-style-type: none"> • Geluidsreductie door laserornamenten 	<ul style="list-style-type: none"> • Geschikt voor accumachines en netsnoer machines





Producteigenschappen						Bestelinformatie					
Ø D [mm]	B [mm]	b [mm]	Ø d [mm]	Z	Snijkwaliteit*		Spaanhoek [°]		VE [St.]	V	ID - No
136	1,6	1,2	20	36	▲▲	Dewalt	-3		1	L	58808600
160	1,8	1,2	20	48	▲▲	Mafell, Festool	-3		1	L	58808605
165	1,8	1,2	20	48	▲▲	Makita, Dewalt, Bosch	-3		1	L	58808606
168	1,8	1,2	20	48	▲▲▲▲	Mafell, Festool	-3		1	L	58808603

* Snijkwaliteit ▲ Zeer grove snede, ▲▲ Grove snede, ▲▲▲ Fijne snede, ▲▲▲▲ Zeer fijne snede

** Extra gaten: Combi1 komt overeen met 2/10/60 + 2/7/42 Combi2 komt overeen met 2/7/42 + 2/9/46 en 2/10/60 Combi3 = 2/10/60 + 2/9/46 + 2/9,5/46,5 + 2/7/42 Combi5 = 2/7/110 + 2/9/110 + 2/8,4/130 + 2/14/110 + 4/9/100 + 4/19/120 Combi7 = 2/9/110 + 2/10/80 + 2/11/85 + 2/11/115 + 2/11/148 + 2/14/100 + 2/14/125 + 2/19/120

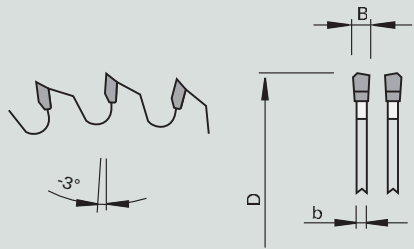
Geschikte reduceerringen vindt u aan het einde van deze catalogus

HW **KKS - Plastic**
Formaatcirkelzaagbladen HW - wisseltand-fase voor kunststoffen

<p>Product</p> 	<p>Tekening</p> 	<p>Machine</p> 	<p>Toepassing</p> 	<p>Uitvoering</p>  <p>2-0-6</p> <p>HW TC06</p> <p>HW TC10</p> <p>WS- FA</p>
--	--	--	---	--

<p>Machine / gebruiksaanwijzing</p> <ul style="list-style-type: none"> • Kap- en radiaal cirkelzagen • Tafelcirkelzagen • Voor zaagsneden in kunststoffen van bijv. PVC, acryl, plexiglas, duroplast materialen, PE, PA, PU, etc. 	<p>Uitvoering</p> <ul style="list-style-type: none"> • Tandvorm: wisseltand-fase "WS-FA" • Tandbezetting: HW TC10 vanaf Ø 250 TC06 	<p>Voordelen</p> <ul style="list-style-type: none"> • Geluidsreductie door laserornamenten 	<p>Informatie - Tip</p> <ul style="list-style-type: none"> • Voorzien van extra teflon-beschermlaag op het stamblad • Zeer geschikt voor gebruik in Polycarbonaatplaat en Lexaanplaat
--	--	---	---

Producteigenschappen										Bestelinformatie			
Ø D [mm]	B [mm]	b [mm]	Ø d [mm]	Z	Snijkwaliteit*	NL**	Spaanhoek [°]	Snijmateriaal		VE [St.]	V	ID - No	
160	2,2	1,6	20	48	▲▲		-3	TC10		1	L	58116000	
190	2,2	1,6	30	54	▲▲		-3	TC10		1	L	58116001	
216	2,8	2,2	30	60	▲▲		-3	TC10		1	L	58116002	
250	2,8	2,2	30	80	▲▲▲	Combi3	-3	TC06		1	L	50808500	
300	2,8	2,2	30	96	▲▲▲	Combi3	-3	TC06		1	L	50808501	
350	2,8	2,2	30	100	▲▲▲	Combi3	-3	TC06		1	L	50808502	



* Snijkwaliteit ▲ Zeer grove snede, ▲▲ Grove snede, ▲▲▲ Fijne snede, ▲▲▲▲ Zeer fijne snede

** Extra gaten: Combi1 komt overeen met 2/10/60 + 2/7/42 Combi2 komt overeen met 2/7/42 + 2/9/46 en 2/10/60 Combi3 = 2/10/60 + 2/9/46 + 2/9,5/46,5 + 2/7/42 Combi5 = 2/7/110 + 2/9/110 + 2/8,4/130 + 2/14/110 + 4/9/100 + 4/19/120 Combi7 = 2/9/110 + 2/10/80 + 2/11/85 + 2/11/115 + 2/11/148 + 2/14/100 + 2/14/125 + 2/19/120
 Geschikte reduceerringen vindt u aan het einde van deze catalogus

HW

KKT - Hard plastic negatief Trespa®

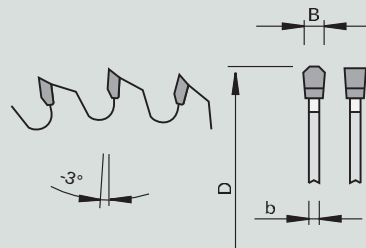
Formaatcirkelzaagbladen HW - trapezium-vlaktand met tweezijdige fase voor zéér harde kunststoffen

Product	Tekening	Machine	Toepassing	Uitvoering
				3-0-1 HW TC04 plus TR-F-FA

Machine / gebruiksaanwijzing	Uitvoering	Voordelen	Informatie - Tip
<ul style="list-style-type: none"> • Handcirkelzagen • Kap- en radiaal cirkelzagen • Tafelcirkelzagen • voor zaagsneden in kunststoffen van bijv. Corian®, Varicor®, Trespa®, laminaat, etc. 	<ul style="list-style-type: none"> • Spaanhoek negatief • Tandvorm: trapezium-vlaktand met tweezijdige fase 'TR-F-FA' • Snijmateriaal HW TC04 plus 	<ul style="list-style-type: none"> • Geluidsreductie door laserornamenten 	

Producteigenschappen								Bestelinformatie			
Ø D [mm]	B [mm]	b [mm]	Ø d [mm]	Z	Snijkwaliteit*	NL**	Spaanhoek [°]	VE [St.]	V	ID - No	
160	2,2	1,6	20	52	▲▲▲	2/6/32	-3	1	L	58808607	
165	2,2	1,6	20	52	▲▲▲	2/6/32	-3	1	L	58808608	
190	2,6	2,0	20FX	54	▲▲▲	Fast-Fix	-3	1	L	58808604	
190	2,5	1,6	30	54	▲▲▲		-3	1	L	58808609	
210	2,8	1,8	30	54	▲▲▲	2/7/42	-3	1	L	58808610	
216	2,8	1,8	30	60	▲▲▲	2/7/42	-3	1	L	58808611	
232	2,8	1,8	30	64	▲▲▲	2/7/42	-3	1	L	58808616	
254	2,4	1,8	30	80	▲▲▲	Combi3	-3	1	L	58808617	
254	2,8	1,8	30	80	▲▲▲	Combi3	-3	1	L	58808612	
260	2,5	1,8	30	80	▲▲▲	Combi3	-3	1	L	58808613	
305	3,2	2,5	30	96	▲▲▲	Combi3	-3	1	L	58808614	

* Snijkwaliteit ▲ Zeer grove snede, ▲▲ Grove snede, ▲▲▲ Fijne snede, ▲▲▲▲ Zeer fijne snede

** Extra gaten: Combi1 komt overeen met 2/10/60 + 2/7/42 Combi2 komt overeen met 2/7/42 + 2/9/46 en 2/10/60 Combi3 = 2/10/60 + 2/9/46 + 2/9,5/46,5 + 2/7/42 Combi5 = 2/7/110 + 2/9/110 + 2/8,4/130 + 2/14/110 + 4/9/100 + 4/19/120 Combi7 = 2/9/110 + 2/10/80 + 2/11/85 + 2/11/115 + 2/11/148 + 2/14/100 + 2/14/125 + 2/19/120

Geschikte reduceerringen vindt u aan het einde van deze catalogus

HW

KKT - Hard plastic positief Trespa®

Cirkelzaagbladen HW - trapezium-vlaktand met tweezijdige fase voor zéér harde kunststoffen

Product



Tekening

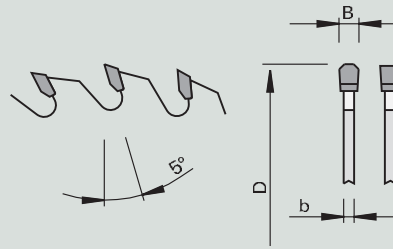

Machine



Toepassing



Uitvoering



3-0-1
HW
TC04
plus

TR-
F-FA

Machine / gebruiksaanwijzing

- Tafelcirkelzagen / stationair
- voor zaagsneden in kunststoffen van bijv. Corian®, Varicor®, Trespa®, Alucobond®, laminaat, etc.

Uitvoering

- Spaanhoek positief
- Tandvorm: trapezium-vlaktand met tweezijdige fase "TR-F-FA"
- Snijmateriaal HW TC04 plus

Voordelen

- Geluidsreductie door laserornamenten

Informatie - Tip

Producteigenschappen

Bestelinformatie

Ø D [mm]	B [mm]	b [mm]	Ø d [mm]	Z	Snijkwaliteit*	NL**	Spaanhoek [°]	VE [St.]	V	ID - No
250	2,8	1,8	30	80	▲▲▲	Combi3	5	1	L	58808620
300	3,2	2,5	30	96	▲▲▲	Combi3	5	1	L	58808621
350	3,5	2,8	30	108	▲▲▲	Combi3	5	1	L	58808622
400	3,5	2,8	30	108	▲▲▲	Combi3	5	1	L	58808623

* Snijkwaliteit ▲ Zeer grove snede, ▲▲ Grove snede, ▲▲▲ Fijne snede, ▲▲▲▲ Zeer fijne snede

** Extra gaten: Combi1 komt overeen met 2/10/60 + 2/7/42 Combi2 komt overeen met 2/7/42 + 2/9/46 en 2/10/60 Combi3 = 2/10/60 + 2/9/46 + 2/9,5/46,5 + 2/7/42 Combi5 = 2/7/110 + 2/9/110 + 2/8,4/130 + 2/14/110 + 4/9/100 + 4/19/120 Combi7 = 2/9/110 + 2/10/80 + 2/11/85 + 2/11/115 + 2/11/148 + 2/14/100 + 2/14/125 + 2/19/120

Geschikte reduceerringen vindt u aan het einde van deze catalogus

DP

KKT - DP Trespa®

Formaat en handcirkelzaagbladen DP - vlakland me fase voor Trespa®



Product	Tekening	Machine	Toepassing	Uitvoering
				2,5 mm
				2-0-6
				3-0-1
				F-FA

- | | | | |
|---|--|---|---|
| <p>Machine / gebruiksaanwijzing</p> <ul style="list-style-type: none"> • Handcirkelzaagbladen • Voor formaatsneden in laminaat, MDF, spaanplaat, Trespa®/ Volkern® platen, Corian®, Duroplast, gipsplaten en Melamine | <p>Uitvoering</p> <ul style="list-style-type: none"> • Tandvorm: vlakland met fase 'F-FA' • Snijmateriaal: DP • Naslijpzone 2,5 mm • Stamblad gecoat | <p>Voordelen</p> <ul style="list-style-type: none"> • Uitermate geschikt voor Trespa®/ Volkern® • Uitstekende spaanafvoer door grote spaanruimte • Stabiele uitvoering | <p>Informatie - Tip</p> <ul style="list-style-type: none"> • Met diamant worden ook in Trespa® hoge standtijden bereikt • Niet inzetbaar voor steen, glas en nagels/ spijkers |
|---|--|---|---|

Producteigenschappen								Bestelinformatie			
Ø D [mm]	B [mm]	b [mm]	Ø d [mm]	Z	Snijkwaliteit*	NL**	Spaanhoek [°]	VE [St.]	V	ID - No	
160	1,8	1,2	20	20	▲▲▲	2/6/32,5	-3		1	L 58458804	
160	2,2	1,8	20	20	▲▲▲	2/6/32,5	-3		1	L 58458803	
168	1,8	1,2	20	20	▲▲▲	2/6/32,5	-3		1	L 58458805	
190	2,4	1,8	30	24	▲▲▲	Combi	-3		1	L 58458809	
216	2,4	1,8	30	28	▲▲▲	Combi	-3		1	L 58458806	
254	2,4	1,8	30	30	▲▲▲	Combi	-3		1	L 58458807	
305	2,5	2,2	30	36	▲▲▲	Combi	-3		1	L 58458808	

* Snijkwaliteit ▲ Zeer grove snede, ▲▲ Grove snede, ▲▲▲ Fijne snede, ▲▲▲▲ Zeer fijne snede

** Extra gaten: Combi1 komt overeen met 2/10/60 + 2/7/42 Combi2 komt overeen met 2/7/42 + 2/9/46 en 2/10/60 Combi3 = 2/10/60 + 2/9/46 + 2/9,5/46,5 + 2/7/42 Combi5 = 2/7/110 + 2/9/110 + 2/8,4/130 + 2/14/110 + 4/9/100 + 4/19/120 Combi7 = 2/9/110 + 2/10/80 + 2/11/85 + 2/11/115 + 2/11/148 + 2/14/100 + 2/14/125 + 2/19/120

Geschikte reduceerringen vindt u aan het einde van deze catalogus

Reduceerringen - gekarteld (vertand)

Voor cirkelzaagbladen

Product

Tekening

Machine

Toepassing

Uitvoering

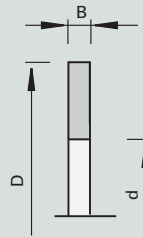

Machine / gebruiksaanwijzing

- Cirkelzaagbladen
- Voor asgat reductie

Uitvoering

- Geslepen asgat
- Uitwendig vertand

Voordelen

Informatie - Tip

- Het asgat kan alleen gereduceerd worden wanneer de opspanning van het zaagblad door spanningen of dmv flens gewaarborgd is

Producteigenschappen

Bestelinformatie

Ø D [mm]	B [mm]	Ø d [mm]							VE [St.]	V	ID - No
15	1,4	10							5	L	50881510
15	1,4	12,7							1	L	50881512
16	1,2	12							1	L	50880034
16	1,4	12,7							1	L	50881612
16	1,2	13							1	L	50880046
16	1,4	13							1	L	50880030
20	1,0	10							1	L	50882010
20	1,2	12							1	L	50880035
20	1,4	12							1	L	50882012
20	1,4	12,7							1	L	50880032
20	1,2	13							1	L	50880047
20	1,4	13							1	L	50880029
20	1,2	15							1	L	50880048
20	1,4	15							1	L	50880028
20	1,4	15,88							1	L	50880108
20	1,0	16							1	L	50882016
20	1,2	16							1	L	50880049
20	1,4	16							1	L	50880027
20	2,0	16							1	L	50880043
20	2,0	19							1	L	50882019
22	1,4	16							1	L	50882216
22	1,4	20							1	L	10001104
22	2,0	20							1	L	50880036
22	2,0	20							1	L	50882222
25	1,4	16							1	L	50880039
25	1,4	16							1	L	50882546
25	2,0	16							1	L	50882516
25	2,0	18							1	L	50880103
25	1,4	20							1	L	50880038
25	1,4	20							1	L	50882624
25	2,0	20							1	L	50880104
25	2,0	20							1	L	50882620
25	1,4	22,2							1	L	50882522
25	2,0	22,2							1	L	50882622
30	2,0	15,88							1	L	50883015
30	1,0	16							1	L	50883016
30	1,4	16							1	L	50880031
30	2,0	16							1	L	50880044
30	1,4	18							1	L	50883418

* Snijkwaliteit ▲ Zeer grove snede, ▲▲ Grove snede, ▲▲▲ Fijne snede, ▲▲▲▲ Zeer fijne snede

** Extra gaten: Combi1 komt overeen met 2/10/60 + 2/7/42 Combi2 komt overeen met 2/7/42 + 2/9/46 en 2/10/60 Combi3 = 2/10/60 + 2/9/46 + 2/9,5/46,5 + 2/7/42 Combi5 = 2/7/110 + 2/9/110 + 2/8,4/130 + 2/14/110 + 4/9/100 + 4/19/120 Combi7 = 2/9/110 + 2/10/80 + 2/11/85 + 2/11/115 + 2/11/148 + 2/14/100 + 2/14/125 + 2/19/120

Geschikte reduceerringen vindt u aan het einde van deze catalogus

Reduceerringen - gekarteld (vertand)

Voor cirkelzaagbladen

Product Tekening Machine Toepassing Uitvoering

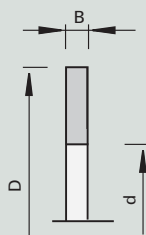

Machine / gebruiksaanwijzing

- Cirkelzaagbladen
- Voor asgat reductie

Uitvoering

- Geslepen asgat
- Uitwendig vertand

Voordelen

Informatie - Tip

- Het asgat kan alleen gereduceerd worden wanneer de opspanning van het zaagblad door spanningen of dmv flens gewaarborgd is

Producteigenschappen

Bestelinformatie

Ø D [mm]	B [mm]	Ø d [mm]	VE [St.]	V	ID - No
30	1,4	19	1	L	50883419
30	2,0	19	1	L	50883019
30	1,0	20	1	L	50883020
30	1,4	20	1	L	50880026
30	2,0	20	1	L	50880045
30	2,0	22	1	L	50880033
30	2,0	22,2	1	L	50883022
30	2,0	24	1	L	50880009
30	1,4	25	1	L	50880008
30	2,0	25	1	L	50880042
30	1,4	25,4	1	L	50883025
30	2,0	25,4	1	L	50880006
32	1,4	20	1	L	50883224
32	2,0	20	1	L	50883220
32	1,4	25	1	L	50883225
32	1,4	30	1	L	50883234
35	1,4	20	1	L	50883524
35	2,0	20	1	L	50883520
35	1,4	25	1	L	50883526
35	2,0	25	1	L	50880002
35	1,4	30	1	L	50883534
35	2,0	30	1	L	50880040
35	1,4	32	1	L	50883532
40	2,0	25	1	L	50880041
40	2,0	30	1	L	50880001

* **Snijkwaliteit** ▲ Zeer grove snede, ▲▲ Grove snede, ▲▲▲ Fijne snede, ▲▲▲▲ Zeer fijne snede

** **Extra gaten: Combi1** komt overeen met 2/10/60 + 2/7/42 **Combi2** komt overeen met 2/7/42 + 2/9/46 en 2/10/60 **Combi3** = 2/10/60 + 2/9/46 + 2/9,5/46,5 + 2/7/42 **Combi5** = 2/7/110 + 2/9/110 + 2/8,4/130 + 2/14/110 + 4/9/100 + 4/19/120 **Combi7** = 2/9/110 + 2/10/80 + 2/11/85 + 2/11/115 + 2/11/148 + 2/14/100 + 2/14/125 + 2/19/120

Geschikte **reduceerringen** vindt u aan het einde van deze catalogus

Reduceerringen - vlak

Voor cirkelzaagbladen

Product

Tekening

Machine

Toepassing

Uitvoering

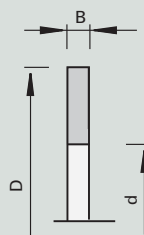

Machine / gebruiksaanwijzing

- Handcirkelzaagbladen
- Voor asgat reductie

Uitvoering

- Geslepen asgat
- Uitwendig vlak

Voordelen

Informatie - Tip

- Het asgat kan alleen gereduceerd worden wanneer de opspanning van het zaagblad door spanningen of dmv flens gewaarborgd is

Producteigenschappen

Bestelinformatie

Ø D [mm]	B [mm]	Ø d [mm]	Ø d [inch]						VE [St.]	V	ID - No
20	1,6	16							1	L	161945
22	2,0	20							1	L	161887
22	4,0	20							1	L	161830
25	2,2	20							1	L	000104
30	1,4	16							1	L	000111
30	1,4	20							1	L	000117
30	1,9	16							1	L	000112
30	1,9	20							1	L	000118
30	2,0	20							1	L	016848
30	2,2	16							1	L	000113
30	2,2	18							1	L	000114
30	2,2	20							1	L	000119
30	2,2	22							1	L	000120
30	2,2	25							1	L	000128
30	2,2	25,4	1"						1	L	000130
30	3,0	25							1	L	000129
30	2,2	28							1	L	000132
32	2,0	16							1	L	161886
32	2,2	30							1	L	000137
35	1,0	30							1	L	000145
35	1,9	30							1	L	000147
35	2,2	25							1	C	000142
35	2,2	30							1	L	000148
40	2,0	32							1	L	161962
40	2,2	20							1	L	000151
40	2,2	30							1	L	000153
45	2,5	30							1	L	161831
50	2,2	30							1	L	000156
55	2,2	30							1	C	000159
60	2,2	30							1	L	000161
60	2,2	35							1	L	000162
60	2,2	50							1	C	000164
60	2,8	30							1	L	010577

* Snijkwaliteit ▲ Zeer grove snede, ▲▲ Grove snede, ▲▲▲ Fijne snede, ▲▲▲▲ Zeer fijne snede

** Extra gaten: Combi1 komt overeen met 2/10/60 + 2/7/42 Combi2 komt overeen met 2/7/42 + 2/9/46 en 2/10/60 Combi3 = 2/10/60 + 2/9/46 + 2/9,5/46,5 + 2/7/42 Combi5 = 2/7/110 + 2/9/110 + 2/8,4/130 + 2/14/110 + 4/9/100 + 4/19/120 Combi7 = 2/9/110 + 2/10/80 + 2/11/85 + 2/11/115 + 2/11/148 + 2/14/100 + 2/14/125 + 2/19/120

Geschikte reduceerringen vindt u aan het einde van deze catalogus

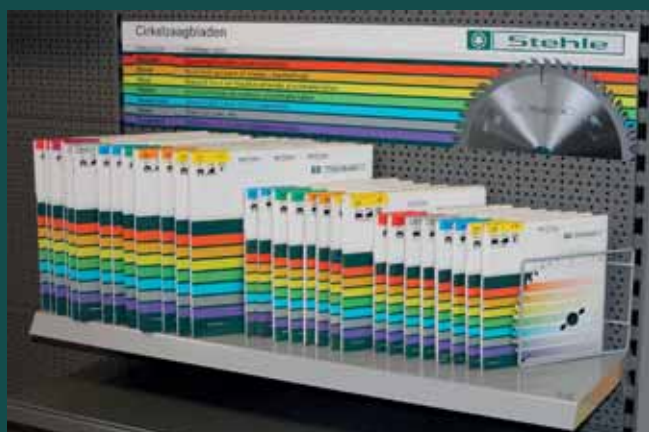

Uw vakhandel:

