

R-HPTII-A4 Stainless Steel Throughbolt

Stainless steel throughbolt anchor for cracked and non-cracked concrete



Approvals and Reports

- ETA 17/0185



Product information

Features and benefits

- Stainless steel anchor for the highest corrosion resistance
- High performance in cracked and non-cracked concrete confirmed by ETA Option 1
- Highest quality ensures maximum load capability
- For applications requiring fire resistance up to 120 minutes
- Suitable for reduced embedment to avoid contact with reinforcement
- Embedment depth markings help to ensure precise installation of the anchor
- Design of R-HPTII allows drilling and installing directly through the fixture and helps to reduce installation time
- Suitable for installation in corrosive environments category C1, C2, C3, C4 and C5

Applications

- Cladding restraints
- Barriers
- Structural steel
- Curtain walling
- Handrails
- Heavy Plant
- Balustrading
- Passenger lifts
- Facades
- Fencing & gates manufacturing and installation
- Masonry support
- Platforms
- Public seating
- Racking systems

Base materials

Approved for use in:

- Cracked concrete C20/25-C50/60
- Non-cracked concrete C20/25-C50/60
- Reinforced concrete
- Unreinforced concrete

Also suitable for use in:

- Natural Stone (after site testing)

Installation guide



1. Drill a hole of required diameter and depth
2. Clear the hole of drilling dust and debris (using blowpump or equivalent method)
3. Lightly tap the throughbolt through the fixture into hole with a hammer, until fixing depth is reached
4. Tighten to the recommended torque

Product information

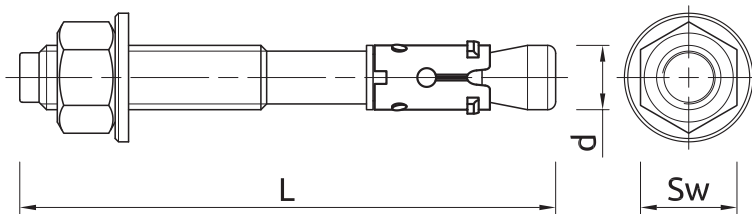

Size	Product Code	Anchor		Fixture		
		Diameter	Length	Max. thickness t_{fix} for:		Hole diameter
		d [mm]	L [mm]	$h_{nom,red}$ [mm]	$h_{nom,std}$ [mm]	d_f [mm]
M8	R-HPTIIA4-08060/10	8	60	10	-	9
	R-HPTIIA4-08075/10	8	75	25	10	9
	R-HPTIIA4-08085/20	8	85	35	20	9
	R-HPTIIA4-08095/30	8	95	45	30	9
	R-HPTIIA4-08105/40	8	105	55	40	9
	R-HPTIIA4-08115/50	8	115	65	50	9
M10	R-HPTIIA4-10065/5	10	65	5	-	11
	R-HPTIIA4-10080/20	10	80	20	-	11
	R-HPTIIA4-10095/15	10	95	35	15	11
	R-HPTIIA4-10115/35	10	115	55	35	11
	R-HPTIIA4-10130/50	10	130	70	50	11
	R-HPTIIA4-10140/60	10	140	80	60	11
M12	R-HPTIIA4-12080/5	12	80	5	-	13
	R-HPTIIA4-12100/5	12	100	25	5	13
	R-HPTIIA4-12115/20	12	115	40	20	13
	R-HPTIIA4-12125/30	12	125	50	30	13
	R-HPTIIA4-12150/55	12	150	75	55	13
	R-HPTIIA4-12180/85	12	180	105	85	13
M16	R-HPTIIA4-16125/5	16	125	25	5	18
	R-HPTIIA4-16140/20	16	140	40	20	18
	R-HPTIIA4-16150/30	16	150	50	30	18
	R-HPTIIA4-16180/60	16	180	80	60	18

Installation data

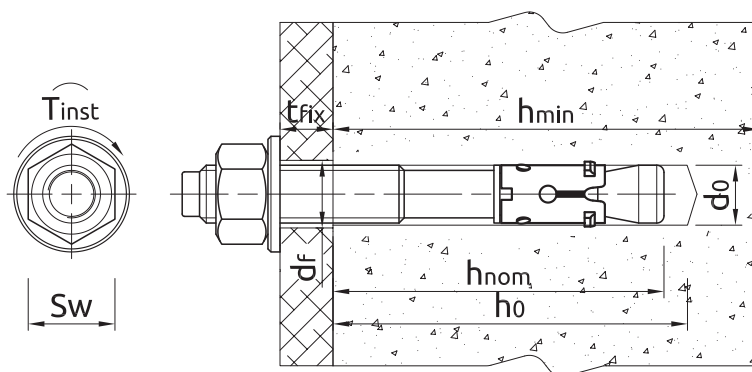

Size		M8	M10	M12	M16
Thread diameter	d [mm]	8	10	12	16
Hole diameter in substrate	d_0 [mm]	8	10	12	16
Installation torque	T_{inst} [Nm]	15	30	50	100
Wrench size	Sw [mm]	13	17	19	24
External diameter of washer	[mm]	16	20	24	30

Installation data

Size			M8	M10	M12	M16
STANDARD EMBEDMENT DEPTH						
Min. hole depth in substrate	$h_{0,s}$	[mm]	65	80	90	110
Min. installation depth	$h_{nom,s}$	[mm]	55	69	80	100
Min. substrate thickness	$h_{min,s}$	[mm]	100	120	140	170
Min. spacing (Non-cracked concrete)	$s_{min,s}$	[mm]	55	70	90	135
Min. spacing (Cracked concrete)	$s_{min,s}$	[mm]	55	70	90	135
Min. edge distance (Non-cracked concrete)	$c_{min,s}$	[mm]	40	50	55	80
Min. edge distance (Cracked concrete)	$c_{min,s}$	[mm]	40	45	55	70
REDUCED EMBEDMENT DEPTH						
Min. hole depth in substrate	$h_{0,r}$	[mm]	50	60	70	90
Min. installation depth	$h_{nom,r}$	[mm]	40	49	60	80
Min. substrate thickness	$h_{min,r}$	[mm]	100	100	100	130
Min. spacing (Non-cracked concrete)	$s_{min,r}$	[mm]	50	70	120	150
Min. spacing (Cracked concrete)	$s_{min,r}$	[mm]	50	70	120	150
Min. edge distance (Non-cracked concrete)	$c_{min,r}$	[mm]	50	60	70	90
Min. edge distance (Cracked concrete)	$c_{min,r}$	[mm]	40	50	70	85

Mechanical properties

Size			M8	M10	M12	M16
Nominal ultimate tensile strength - tension	f_{uk}	[N/mm ²]	600	600	550	550
Nominal yield strength - tension	f_{yk}	[N/mm ²]	450	450	413	413
Cross sectional area - tension	A_s	[mm ²]	36.6	58	84.3	157
Elastic section modulus	W_{el}	[mm ³]	50.27	98.17	169.65	402.12
Characteristic bending resistance	$M_{Rk,s}^0$	[Nm]	22	45	72	180
Design bending resistance	M	[Nm]	18	36	57	144

Basic performance data

Performance data for single anchor without influence of edge distance and spacing - ETAG 001

Size		M8	M10	M12	M16
NON-CRACKED CONCRETE					
Standard embedment depth h_{ef}	[mm]	47.00	59.00	68.00	85.00
Reduced embedment depth h_{ef}	[mm]	32.00	39.00	48.00	65.00
CRACKED CONCRETE					
Standard embedment depth h_{ef}	[mm]	47.00	59.00	68.00	85.00
Reduced embedment depth h_{ef}	[mm]	32.00	39.00	48.00	65.00
MEAN ULTIMATE LOAD					
TENSION LOAD $N_{Ru,m}$					
NON-CRACKED CONCRETE					
Standard embedment depth	[kN]	15.40	22.80	29.20	55.80
Reduced embedment depth	[kN]	10.40	16.00	22.10	37.90
CRACKED CONCRETE					
Standard embedment depth	[kN]	9.70	11.50	18.60	30.40
Reduced embedment depth	[kN]	5.60	9.80	13.40	22.20
SHEAR LOAD $V_{Ru,m}$					
NON-CRACKED CONCRETE					
Standard embedment depth	[kN]	14.00	22.20	29.60	54.50
Reduced embedment depth	[kN]	11.80	19.20	29.60	54.50
CRACKED CONCRETE					
Standard embedment depth	[kN]	14.00	21.20	29.60	54.50
Reduced embedment depth	[kN]	8.50	13.60	15.40	54.50

Basic performance data

Size		M8	M10	M12	M16
CHARACTERISTIC LOAD					
TENSION LOAD N_{Rk}					
NON-CRACKED CONCRETE					
Standard embedment depth	[kN]	9.00	16.00	25.00	39.50
Reduced embedment depth	[kN]	7.50	12.00	16.80	26.40
CRACKED CONCRETE					
Standard embedment depth	[kN]	6.00	9.00	12.00	25.00
Reduced embedment depth	[kN]	3.00	7.50	9.00	16.00
SHEAR LOAD V_{Rk}					
NON-CRACKED CONCRETE					
Standard embedment depth	[kN]	11.70	18.50	24.60	45.40
Reduced embedment depth	[kN]	9.14	14.70	16.79	45.40
CRACKED CONCRETE					
Standard embedment depth	[kN]	11.60	16.31	24.60	45.40
Reduced embedment depth	[kN]	6.52	10.52	11.97	37.70
DESIGN LOAD					
TENSION LOAD N_{Rd}					
NON-CRACKED CONCRETE					
Standard embedment depth	[kN]	5.00	10.70	16.70	26.30
Reduced embedment depth	[kN]	4.17	6.67	11.20	17.60
CRACKED CONCRETE					
Standard embedment depth	[kN]	3.33	6.00	8.00	16.70
Reduced embedment depth	[kN]	1.67	4.17	6.00	10.70
SHEAR LOAD V_{Rd}					
NON-CRACKED CONCRETE					
Standard embedment depth	[kN]	9.40	14.80	19.70	36.30
Reduced embedment depth	[kN]	6.09	9.84	11.20	35.30
CRACKED CONCRETE					
Standard embedment depth	[kN]	7.73	10.88	19.68	36.30
Reduced embedment depth	[kN]	4.34	7.01	7.98	25.15
RECOMMENDED LOAD					
TENSION LOAD N_{rec}					
NON-CRACKED CONCRETE					
Standard embedment depth	[kN]	3.57	7.62	11.90	18.80
Reduced embedment depth	[kN]	2.98	4.76	8.00	12.60
CRACKED CONCRETE					
Standard embedment depth	[kN]	2.38	4.29	5.71	11.90
Reduced embedment depth	[kN]	1.19	2.98	4.29	7.62
SHEAR LOAD V_{rec}					
NON-CRACKED CONCRETE					
Standard embedment depth	[kN]	6.69	10.60	14.10	25.90
Reduced embedment depth	[kN]	4.35	7.03	8.00	25.20
CRACKED CONCRETE					
Standard embedment depth	[kN]	5.52	7.77	14.06	25.90
Reduced embedment depth	[kN]	3.10	5.01	5.70	18.00

Design performance data

Standard embedment depth

(-) failure is not decisive

Size			M8	M10	M12	M16
Effective embedment depth	h_{ef}	[mm]	47.00	59.00	68.00	85.00
TENSION LOAD						
STEEL FAILURE						
Characteristic resistance	$N_{Rk,s}$	[kN]	21.20	33.60	44.80	82.60
Partial safety factor	γ_{Ms}	-	1.50	1.50	1.50	1.50
PULL-OUT FAILURE; NON-CRACKED CONCRETE C20/25						
Characteristic resistance	$N_{Rk,p}$	[kN]	9.00	16.00	25.00	-
PULL-OUT FAILURE; CRACKED CONCRETE C20/25						
Characteristic resistance	$N_{Rk,p}$	[kN]	6.00	9.00	12.00	25.00
PULL-OUT FAILURE						
Installation safety factor	γ_2	-	1.20	1.00	1.00	1.00
Increasing factors for $N_{Rd,p}$ - C30/37	ψ_c	-	1.16	1.26	1.23	1.18
Increasing factors for $N_{Rd,p}$ - C40/50	ψ_c	-	1.33	1.52	1.45	1.37
Increasing factors for $N_{Rd,p}$ - C50/60	ψ_c	-	1.50	1.78	1.67	1.55
CONCRETE CONE FAILURE						
Factor for cracked concrete	k	-	7.20	7.20	7.20	7.20
Factor for cracked concrete	$k_{cr,N}$	-	7.70	7.70	7.70	7.70
Factor for non-cracked concrete	k	-	10.10	10.10	10.10	10.10
Factor for non-cracked concrete	$k_{ucr,N}$	-	11.00	11.00	11.00	11.00
Installation safety factor	γ_2	-	1.20	1.00	1.00	1.00
Spacing	$s_{cr,N}$	[mm]	141.00	177.00	204.00	255.00
Edge distance	$c_{cr,N}$	[mm]	71.00	89.00	102.00	128.00
CONCRETE SPLITTING FAILURE						
Spacing	$s_{cr,sp}$	[mm]	240.00	300.00	340.00	430.00
Edge distance	$c_{cr,sp}$	[mm]	120.00	150.00	170.00	215.00
Installation safety factor	γ_2	-	1.20	1.00	1.00	1.00
SHEAR LOAD						
STEEL FAILURE						
Characteristic resistance without lever arm	$V_{Rk,s}$	[kN]	11.70	18.50	24.60	45.40
Ductility factor	k_γ	-	0.80	0.80	0.80	0.80
Characteristic resistance with lever arm	$M_{Rk,s}$	[Nm]	22.00	45.00	72.00	180.00
Partial safety factor	γ_{Ms}	-	1.25	1.25	1.25	1.25
CONCRETE PRY-OUT FAILURE						
Factor	k	-	1.00	1.00	2.00	2.00
Installation safety factor	γ_2	-	1.00	1.00	1.00	1.00
CONCRETE EDGE FAILURE						
Effective length of anchor	ℓ_f	[mm]	47.00	59.00	68.00	85.00
Anchor diameter	d_{nom}	[mm]	8.00	10.00	12.00	16.00
Installation safety factor	γ_2	-	1.00	1.00	1.00	1.00

Design performance data

Resistance to tension and shear loads under fire exposure - Standard embedment depth

Size			M8	M10	M12	M16
R (for EI) = 30 min						
TENSION LOAD						
STEEL FAILURE						
Characteristic resistance	$N_{Rk,s}$	[kN]	0.70	1.50	2.50	4.70
PULL-OUT FAILURE						
Characteristic resistance	$N_{Rk,p}$	[kN]	1.50	2.30	3.00	6.30
CONCRETE CONE FAILURE						
Characteristic resistance	$N_{Rk,c}$	[kN]	2.70	4.80	6.90	12.00
SHEAR LOAD						
STEEL FAILURE						
Characteristic resistance without lever arm	$V_{Rk,s}$	[kN]	0.70	1.50	2.50	4.70
Characteristic resistance with lever arm	$M_{Rk,s}$	[kN]	0.70	1.90	3.90	10.00
R (for EI) = 60 min						
TENSION LOAD						
STEEL FAILURE						
Characteristic resistance	$N_{Rk,s}$	[kN]	0.60	1.20	2.10	3.90
PULL-OUT FAILURE						
Characteristic resistance	$N_{Rk,p}$	[kN]	1.50	2.30	3.00	6.30
CONCRETE CONE FAILURE						
Characteristic resistance	$N_{Rk,c}$	[kN]	2.70	4.80	6.90	12.00
SHEAR LOAD						
STEEL FAILURE						
Characteristic resistance without lever arm	$V_{Rk,s}$	[kN]	0.60	1.20	2.10	3.90
Characteristic resistance with lever arm	$M_{Rk,s}$	[kN]	0.60	1.50	3.30	8.30
R (for EI) = 90 min						
TENSION LOAD						
STEEL FAILURE						
Characteristic resistance	$N_{Rk,s}$	[kN]	0.40	0.90	1.70	3.10
PULL-OUT FAILURE						
Characteristic resistance	$N_{Rk,p}$	[kN]	1.50	2.30	3.00	6.30
CONCRETE CONE FAILURE						
Characteristic resistance	$N_{Rk,c}$	[kN]	2.70	4.80	6.90	12.00
SHEAR LOAD						
STEEL FAILURE						
Characteristic resistance without lever arm	$V_{Rk,s}$	[kN]	0.40	0.90	1.70	3.10
Characteristic resistance with lever arm	$M_{Rk,s}$	[kN]	0.40	1.20	2.60	6.70
R (for EI) = 120 min						
TENSION LOAD						
STEEL FAILURE						
Characteristic resistance	$N_{Rk,s}$	[kN]	0.40	0.80	1.30	2.50
PULL-OUT FAILURE						
Characteristic resistance	$N_{Rk,p}$	[kN]	1.20	1.80	2.40	5.00
CONCRETE CONE FAILURE						
Characteristic resistance	$N_{Rk,c}$	[kN]	2.20	3.90	5.50	9.60
SHEAR LOAD						
STEEL FAILURE						
Characteristic resistance without lever arm	$V_{Rk,s}$	[kN]	0.40	0.80	1.30	2.50
Characteristic resistance with lever arm	$M_{Rk,s}$	[kN]	0.40	1.00	2.10	5.30

Design performance data

Allowable values for resistance in case of Seismic performance category C1 - Standard embedment depth

Size			M8	M10	M12	M16
Effective embedment depth	h_{ef}	[mm]	47.00	59.00	68.00	85.00
TENSION LOAD, STEEL FAILURE						
Characteristic resistance	$N_{Rk,s}$	[kN]	21.20	33.60	44.80	82.60
Partial safety factor	$\gamma_{MsN,seisC1}$	-	1.50			
TENSION LOAD, PULL-OUT FAILURE						
Characteristic resistance	$N_{Rk,p}$	[kN]	6.00	9.00	12.00	25.00
Partial safety factor	$\gamma_{Mp,seisC1}$	-	1.80	1.50		
SHEAR LOAD, STEEL FAILURE						
Characteristic resistance without lever arm	$V_{Rk,s}$	[kN]	6.70	12.50	18.40	39.00
Partial safety factor	$\gamma_{MsVs,seisC1}$	-	1.25			

Reduced embedment depth

(-) failure is not decisive

Size			M8	M10	M12	M16
Effective embedment depth	h_{ef}	[mm]	32.00	39.00	48.00	65.00
TENSION LOAD						
STEEL FAILURE						
Characteristic resistance	$N_{Rk,s}$	[kN]	21.20	33.60	44.80	82.60
Partial safety factor	γ_{Ms}	-	1.50	1.50	1.50	1.50
PULL-OUT FAILURE; NON-CRACKED CONCRETE C20/25						
Characteristic resistance	$N_{Rk,p}$	[kN]	7.50	12.00	-	-
PULL-OUT FAILURE; CRACKED CONCRETE C20/25						
Characteristic resistance	$N_{Rk,p}$	[kN]	3.00	7.50	9.00	16.00
PULL-OUT FAILURE						
Installation safety factor	γ_2	-	1.20	1.20	1.00	1.00
Increasing factors for $N_{Rd,p}$ - C30/37	ψ_c	-	1.07	1.07	1.16	1.18
Increasing factors for $N_{Rd,p}$ - C40/50	ψ_c	-	1.13	1.13	1.32	1.37
Increasing factors for $N_{Rd,p}$ - C50/60	ψ_c	-	1.20	1.20	1.49	1.55
CONCRETE CONE FAILURE						
Factor for cracked concrete	k	-	7.20	7.20	7.20	7.20
Factor for cracked concrete	$k_{cr,N}$	-	7.70	7.70	7.70	7.70
Factor for non-cracked concrete	k	-	10.10	10.10	10.10	10.10
Factor for non-cracked concrete	$k_{ucr,N}$	-	11.00	11.00	11.00	11.00
Installation safety factor	γ_2	-	1.20	1.20	1.00	1.00
Spacing	$s_{cr,N}$	[mm]	96.00	117.00	144.00	195.00
Edge distance	$c_{cr,N}$	[mm]	48.00	59.00	72.00	98.00
CONCRETE SPLITTING FAILURE						
Spacing	$s_{cr,sp}$	[mm]	160.00	200.00	250.00	320.00
Edge distance	$c_{cr,sp}$	[mm]	80.00	100.00	125.00	160.00
Installation safety factor	γ_2	-	1.20	1.20	1.00	1.00

Design performance data

Size			M8	M10	M12	M16
SHEAR LOAD						
STEEL FAILURE						
Characteristic resistance without lever arm	$V_{Rk,s}$	[kN]	11.70	18.50	24.60	45.40
Ductility factor	k_γ	-	0.80	0.80	0.80	0.80
Characteristic resistance with lever arm	$M_{Rk,s}$	[Nm]	22.00	42.00	72.00	180.00
Partial safety factor	γ_{Ms}	-	1.25	1.25	1.25	1.25
CONCRETE PRY-OUT FAILURE						
Factor	k	-	1.00	1.00	1.00	2.00
Installation safety factor	γ_2	-	1.00	1.00	1.00	1.00
CONCRETE EDGE FAILURE						
Effective length of anchor	l_f	[mm]	32.00	39.00	48.00	65.00
Anchor diameter	d_{nom}	[mm]	8.00	10.00	12.00	16.00
Installation safety factor	γ_2	-	1.00	1.00	1.00	1.00

Design performance data

Resistance to tension and shear loads under fire exposure - Reduced embedment depth

Size			M8	M10	M12	M16
R (for EI) = 30 min						
TENSION LOAD						
STEEL FAILURE						
Characteristic resistance	$N_{Rk,s}$	[kN]	0.70	1.50	2.50	4.70
PULL-OUT FAILURE						
Characteristic resistance	$N_{Rk,p}$	[kN]	0.80	1.90	2.30	4.00
CONCRETE CONE FAILURE						
Characteristic resistance	$N_{Rk,c}$	[kN]	1.00	1.70	2.90	6.10
SHEAR LOAD						
STEEL FAILURE						
Characteristic resistance without lever arm	$V_{Rk,s}$	[kN]	0.70	1.50	2.50	4.70
Characteristic resistance with lever arm	$M_{Rk,s}$	[kN]	0.70	1.90	3.90	10.00
R (for EI) = 60 min						
TENSION LOAD						
STEEL FAILURE						
Characteristic resistance	$N_{Rk,s}$	[kN]	0.60	1.20	2.10	3.90
PULL-OUT FAILURE						
Characteristic resistance	$N_{Rk,p}$	[kN]	0.80	1.90	2.30	4.00
CONCRETE CONE FAILURE						
Characteristic resistance	$N_{Rk,c}$	[kN]	1.00	1.70	2.90	6.10
SHEAR LOAD						
STEEL FAILURE						
Characteristic resistance without lever arm	$V_{Rk,s}$	[kN]	0.60	1.20	2.10	3.90
Characteristic resistance with lever arm	$M_{Rk,s}$	[kN]	0.60	1.50	3.30	8.30
R (for EI) = 90 min						
TENSION LOAD						
STEEL FAILURE						
Characteristic resistance	$N_{Rk,s}$	[kN]	0.40	0.90	1.70	3.10
PULL-OUT FAILURE						
Characteristic resistance	$N_{Rk,p}$	[kN]	0.80	1.90	2.30	4.00
CONCRETE CONE FAILURE						
Characteristic resistance	$N_{Rk,c}$	[kN]	1.00	1.70	2.90	6.10
SHEAR LOAD						
STEEL FAILURE						
Characteristic resistance without lever arm	$V_{Rk,s}$	[kN]	0.40	0.90	1.70	3.10
Characteristic resistance with lever arm	$M_{Rk,s}$	[kN]	0.40	1.20	2.60	6.70
R (for EI) = 120 min						
TENSION LOAD						
STEEL FAILURE						
Characteristic resistance	$N_{Rk,s}$	[kN]	0.40	0.80	1.30	2.50
PULL-OUT FAILURE						
Characteristic resistance	$N_{Rk,p}$	[kN]	0.60	1.50	1.80	3.20
CONCRETE CONE FAILURE						
Characteristic resistance	$N_{Rk,c}$	[kN]	0.80	1.40	2.30	4.90
SHEAR LOAD						
STEEL FAILURE						
Characteristic resistance without lever arm	$V_{Rk,s}$	[kN]	0.40	0.80	1.30	2.50
Characteristic resistance with lever arm	$M_{Rk,s}$	[kN]	0.40	1.00	2.10	5.30

Design performance data

Allowable values for resistance in case of Seismic performance category C1 - Reduced embedment depth

Size			M8	M10	M12	M16
Effective embedment depth	h_{ef}	[mm]	32.00	39.00	48.00	65.00
TENSION LOAD, STEEL FAILURE						
Characteristic resistance	$N_{Rk,s}$	[kN]	21.20	33.60	44.80	82.60
Partial safety factor	$\gamma_{MsN,seisC1}$	-	1.50			
TENSION LOAD, PULL-OUT FAILURE						
Characteristic resistance	$N_{Rk,p}$	[kN]	3.00	7.50	9.00	16.00
Partial safety factor	$\gamma_{Mp,seisC1}$	-	1.80		1.50	
SHEAR LOAD, STEEL FAILURE						
Characteristic resistance without lever arm	$V_{Rk,s}$	[kN]	-		18.40	39.00
Partial safety factor	$\gamma_{MsV,seisC1}$	-	1.25			

Product commercial data

Size	Product Code	Anchor		Quantity [pcs]			Weight [kg]			Bar Codes
		Diameter [mm]	Length [mm]	Box	Outer	Pallet	Box	Outer	Pallet	
M8	R-HPTIIA4-08060/10 ¹⁾	8	60	100	100	16000	2.6	2.6	441.0	5906675046419
	R-HPTIIA4-08075/10 ¹⁾	8	75	100	100	16000	3.1	3.1	519.6	5906675046426
	R-HPTIIA4-08085/20 ¹⁾	8	85	100	100	16000	3.3	3.3	563.6	5906675046433
	R-HPTIIA4-08095/30 ¹⁾	8	95	100	100	12000	3.3	3.3	426.0	5906675046440
	R-HPTIIA4-08105/40 ¹⁾	8	105	50	50	16000	2.2	2.2	734.0	5906675046457
	R-HPTIIA4-08115/50 ¹⁾	8	115	100	100	16000	4.3	4.3	717.0	5906675046464
M10	R-HPTIIA4-10065/5 ¹⁾	10	65	50	50	8000	2.4	2.4	409.0	5906675046471
	R-HPTIIA4-10080/20 ¹⁾	10	80	50	50	8000	2.8	2.8	469.7	5906675046488
	R-HPTIIA4-10095/15 ¹⁾	10	95	50	50	8000	3.1	3.1	529.7	5906675046495
	R-HPTIIA4-10115/35 ¹⁾	10	115	50	50	6000	3.7	3.7	468.1	5906675046501
	R-HPTIIA4-10130/50 ¹⁾	10	130	50	50	6000	4.0	4.0	508.3	5906675046518
	R-HPTIIA4-10140/60 ¹⁾	10	140	50	50	8000	4.2	4.2	707.0	5906675046532
M12	R-HPTIIA4-12080/5 ¹⁾	12	80	50	50	8000	4.1	4.1	688.7	5906675046549
	R-HPTIIA4-12100/5 ¹⁾	12	100	50	50	8000	4.8	4.8	797.4	5906675046556
	R-HPTIIA4-12115/20 ¹⁾	12	115	50	50	6000	7.0	7.0	870.0	5906675388106
	R-HPTIIA4-12125/30 ¹⁾	12	125	50	50	6000	5.8	5.8	721.9	5906675046563
	R-HPTIIA4-12150/55 ¹⁾	12	150	50	50	4000	6.7	6.7	561.6	5906675046570
	R-HPTIIA4-12180/85 ¹⁾	12	180	50	50	4000	7.8	7.8	651.3	5906675046587
M16	R-HPTIIA4-16125/5 ¹⁾	16	125	25	25	4000	5.4	5.4	888.2	5906675046594
	R-HPTIIA4-16140/20 ¹⁾	16	140	25	25	4000	5.8	5.8	957.4	5906675034898
	R-HPTIIA4-16150/30 ¹⁾	16	150	25	25	4000	6.1	6.1	1006.5	5906675046600
	R-HPTIIA4-16180/60 ¹⁾	16	180	25	25	3000	7.2	7.2	888.7	5906675046617

1) ETA 17/0185